

# TYRANNY LIBERATOR



Seamless backup power. With or without solar.

Copyright © DIY Power Wall 2019



GENERAL INFORMATION

## CONTENTS

<b>Grid-Tie Solar Systems</b> .....	5
➤ <b>Advantages of Grid-Tied Systems</b> .....	5
➤ <b>Equipment for Grid-Tie Solar Systems</b> .....	7
<b>Off-Grid Solar Systems</b> .....	8
➤ <b>Advantages of Off-Grid Systems</b> .....	8
➤ <b>Equipment for Off-Grid Systems</b> .....	9
<b>Hybrid Solar Systems</b> .....	11
➤ <b>Advantages of Hybrid Solar Systems</b> .....	11
➤ <b>Equipment for Hybrid Solar Systems</b> .....	12
<b>Why a DC System is Not Feasible</b> .....	13
<b>Different Types of Inverters</b> .....	14
➤ <b>Off-Grid Inverter</b> .....	14
➤ <b>On-Grid Inverter</b> .....	14
➤ <b>Grid Tied (Grid Synchronized) Inverter</b> .....	14
<b>Cells, Modules and Arrays</b> .....	16
➤ <b>Solar Cells</b> .....	16
➤ <b>The Photovoltaic Effect</b> .....	17
➤ <b>Silicon Solar Cells</b> .....	17
➤ <b>Crystalline Silicon Wafer Production</b> .....	18
➤ <b>Monocrystalline Wafer Production: Czochralski Method</b> .....	18
➤ <b>Polycrystalline Silicon Wafer Production</b> .....	19
➤ <b>Solar Cell Manufacturing</b> .....	19
➤ <b>Flat-Plate PV Modules</b> .....	20
➤ <b>Typical PV Module Construction</b> .....	21
➤ <b>Emerging PV Module Technologies</b> .....	21
➤ <b>Thin-Film PV Modules</b> .....	22
➤ <b>Concentrating PV Modules</b> .....	23
➤ <b>Ac Modules and Micro-Inverters</b> .....	23
➤ <b>Leading Manufacturers of PC Cells AND Modules</b> .....	24
➤ <b>Current-Voltage (I-V) Characteristics</b> .....	24
➤ <b>Key I-V Parameters</b> .....	25
➤ <b>Power vs. Voltage Curve</b> .....	25

➤	<b>PV Module Rating Conditions</b> .....	26
➤	<b>Fill Factor</b> .....	26
➤	<b>Efficiency</b> .....	27
➤	<b>Response to Electrical Load</b> .....	28
➤	<b>Operating Point</b> .....	28
➤	<b>PV Modules for Battery Charging</b> .....	29
➤	<b>Effect of Electrical Load on Operating Point</b> .....	29
➤	<b>I-V Measurement Methods</b> .....	30
➤	<b>Solmetric PVA-600 PV Analyzer</b> .....	30
➤	<b>Raydec DS-100 IV Curve Tracer</b> .....	31
➤	<b>Spire 4600 SLP Flash Simulator</b> .....	31
➤	<b>Response to Electrical Load: Example</b> .....	32
➤	<b>Solar Cell Equivalent Circuit</b> .....	32
➤	<b>Series Resistance</b> .....	32
➤	<b>Shunt Resistance</b> .....	33
➤	<b>Response to Solar Irradiance</b> .....	33
➤	<b>Response to Temperature</b> .....	35
➤	<b>Temperature-Rise Coefficient</b> .....	35
➤	<b>Temperature Coefficient</b> .....	36
➤	<b>Temperature Coefficient</b> .....	36
➤	<b>Response to Temperature: Example 1</b> .....	37
➤	<b>Response to Temperature: Example 2</b> .....	37
➤	<b>Building PV Arrays</b> .....	38
➤	<b>Monopole and Bipolar PV Arrays</b> .....	38
➤	<b>Connecting Similar PV Devices in Series</b> .....	39
➤	<b>I-V Curves for Similar PV Devices in Series</b> .....	39
➤	<b>Dissimilar PV Devices in Series</b> .....	40
➤	<b>Connecting PV Devices in Parallel</b> .....	40
➤	<b>I-V Curves for Similar PV Devices in Parallel</b> .....	41
➤	<b>Connecting Dissimilar PV Devices in Parallel</b> .....	41
➤	<b>Bypass Diodes</b> .....	42
➤	<b>Without Bypass Diodes</b> .....	43
➤	<b>With Bypass Diodes</b> .....	43

- **Module Junction Box with Bypass Diodes**..... 44
- **PV Module Rating Conditions** ..... 44
- **Other PV Module Ratings**..... 45
- **PV Module Rating Conditions** ..... 45
- **Approved Modules**..... 46
- **Photovoltaic Modules Standards**..... 46
- **PV Modules Markings** ..... 46
- **Fire Classification**..... 47
- **PV Modules Design Qualification** ..... 47
- **Module Installation Instructions** ..... 47
- **PV Module Safety** ..... 48
- **Handling PV Modules** ..... 48
- **Module Selection Criteria** ..... 49
- **Summary**..... 49

**What are the benefits of grid-connected solar panels vs. living off the grid?** Deciding whether or not to grid-tie your solar panels is usually pretty straightforward – the clear-cut benefits of being grid-tied appeals to the majority of homeowners. There are, however, some people that choose to live off the grid.

**What would be the best in your situation?** Let’s look closer at the benefits and downsides of grid-tie, off-grid and hybrid solar systems.

## Grid-Tie Solar Systems

Grid-tied, on-grid, utility-interactive, grid intertie and grid back feeding are all terms used to describe the same concept – a solar system that is connected to the utility power grid.

### ➤ Advantages of Grid-Tied Systems

1. Save more money with net metering

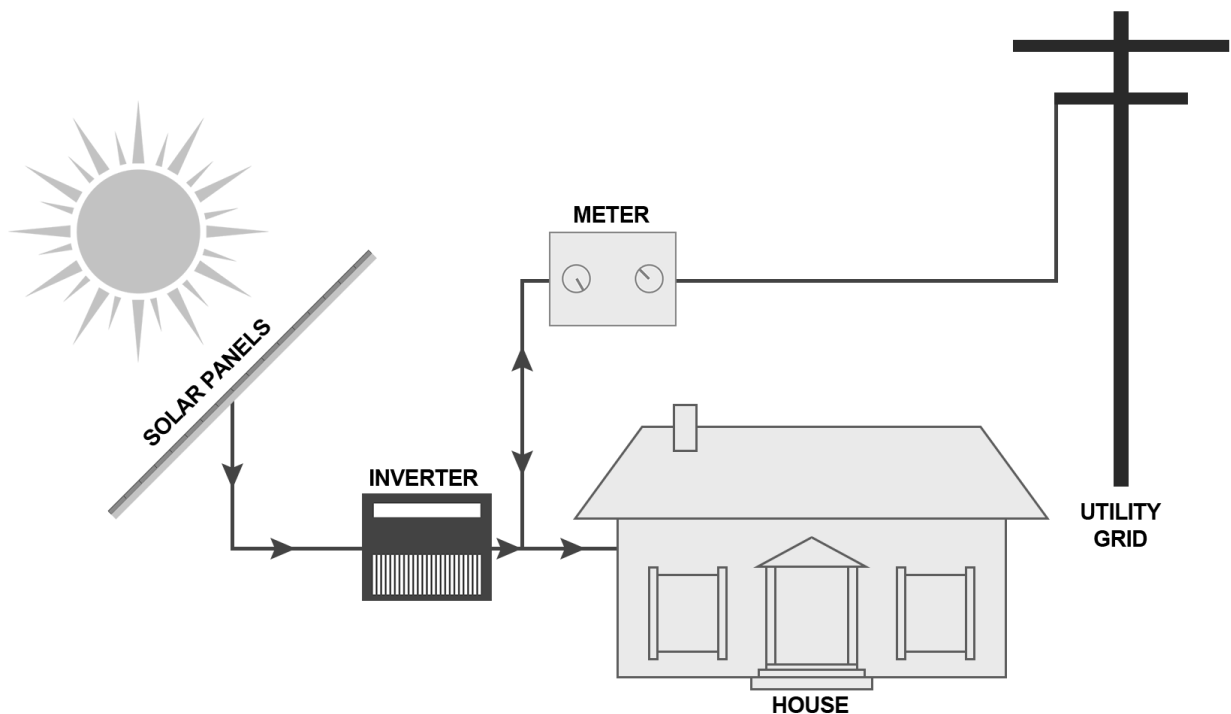

**A grid-connection will allow you to save more money with solar panels through better efficiency rates, net metering, plus lower equipment and installation costs:**

Batteries, and other stand-alone equipment, are required for a fully functional off-grid solar system and add to costs as well as maintenance. Grido install.

Your solar panels will often generate more electricity than what you are capable of consuming. With net metering, homeowners can put this excess electricity onto the utility grid instead of storing it themselves with batteries.

Net metering (or feed-in tariff schemes in some countries) play an important role in how solar power is incentivized. Without it, residential solar systems would be much less feasible from a financial point of view.

Many utility companies are committed to buying electricity from homeowners at the same rate as they sell it themselves.

## 2. The utility grid is a virtual battery

Electricity has to be spent in real time. However, it can be temporarily stored as other forms of energy (e.g. chemical energy in batteries). Energy storage typically comes with significant losses.

**The electric power grid is in many ways also a battery, without the need for maintenance or replacements, and with much better efficiency rates.** In other words, more electricity (and more money) goes to waste with conventional battery systems.

According to EIA data, national, annual electricity transmission and distribution losses average about 7% of the electricity that is transmitted in the United States. Lead-acid batteries, which are commonly used with solar panels, are only 80-90% efficient at storing energy, and their performance degrades with time.

Additional perks of being grid-tied include access to backup power from the utility grid (in case your solar system stop generating electricity for one reason or another). At the same time you help to mitigate the utility company's peak load. As a result, the efficiency of our electrical system as a whole goes up.

## ➤ Equipment for Grid-Tie Solar Systems

There are a few key differences between the equipment needed for grid-tied, off-grid and hybrid solar systems. Standard grid-tied solar systems rely on the following components:

- Grid-Tie Inverter (GTI) or Micro-Inverters
- Power Meter

### 1. Grid-Tie Inverter (GTI)

**What is the job of a solar inverter? They regulate the voltage and current received from your solar panels.** Direct current (DC) from your solar panels is converted into alternating current (AC), which is the type of current that is utilized by the majority of electrical appliances.

In addition to this, grid-tie inverters, also known as grid-interactive or synchronous inverters, synchronize the phase and frequency of the current to fit the utility grid (nominally 60Hz). The output voltage is also adjusted slightly higher than the grid voltage in order for excess electricity to flow outwards to the grid.

### 2. Micro-Inverters

Micro-inverters go on the back of each solar panel, as opposed to one central inverter that typically takes on the entire solar array.

There has recently been a lot of debate on whether micro-inverters are better than central (string) inverters.

Micro-inverters are certainly more expensive, but in many cases yield higher efficiency rates. **Homeowners who are suspect to shading issues should definitely look into if micro-inverters are better in their situation.**

### 3. Power Meter

**Most homeowners will need to replace their current power meter with one that is compatible with net metering.** This device, often called a net meter or a two-way meter, is capable of measuring power going in both directions, from the grid to your house and vice versa.

You should consult with your local utility company and see what net metering options you have. In some places, the utility company issues a power meter for free and pay full price for the electricity you generate; however, this is not always the case.

## Off-Grid Solar Systems

An off-grid solar system (off-the-grid, standalone) is the obvious alternative to one that is grid-tied. For homeowners that have access to the grid, off-grid solar systems are usually out of question. Here`s why:

To ensure access to electricity at all times, off-grid solar systems require battery storage and a backup generator (if you live off-the-grid). On top of this, a battery bank typically needs to be replaced after 10 years. Batteries are complicated, expensive and decrease overall system efficiency.

### ➤ Advantages of Off-Grid Systems

1. No access to the utility grid

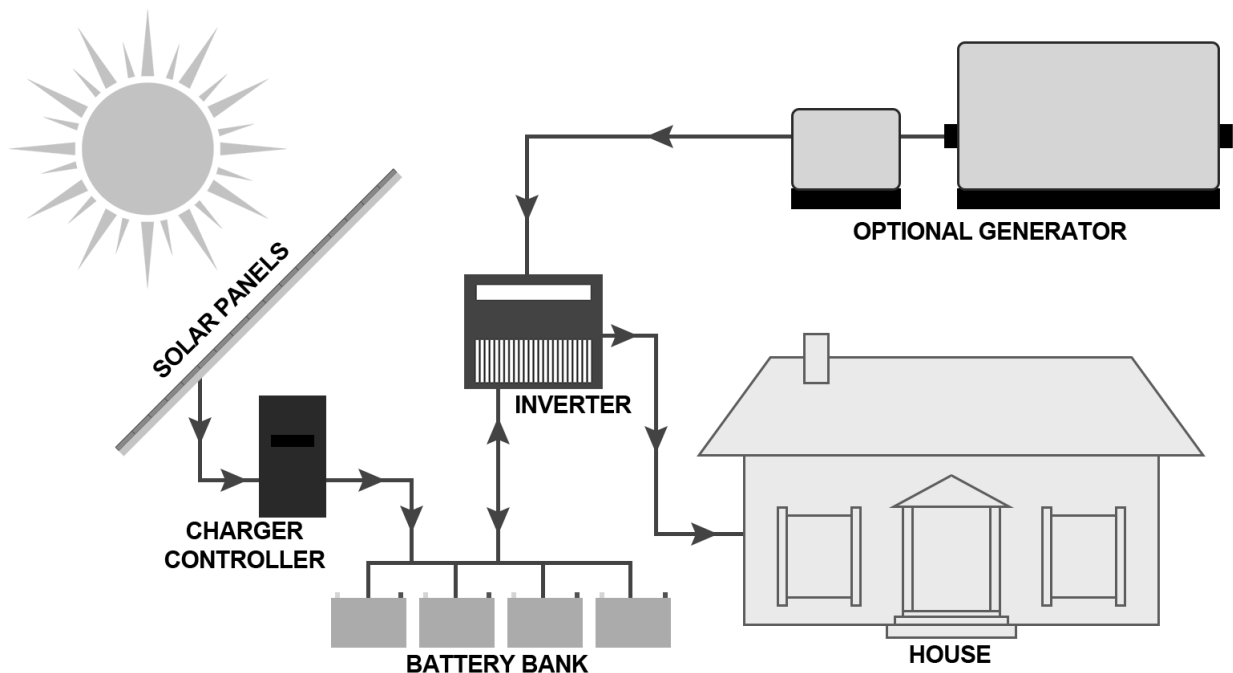

**Off-grid solar systems can be cheaper than extending power lines in certain remote areas.**

Consider off-grid if you're more than 100 yards from the grid. The costs of overhead transmission lines range from \$174,000 per mile (for rural construction) to \$11,000,000 per mile (for urban construction).

## 2. Become energy self-sufficient

**Living off the grid and being self-sufficient feels good.** For some people, this feeling is worth more than saving money. Energy self-sufficiency is also a form of security. Power failures on the utility grid do not affect off-grid solar systems.

On the flip side, batteries can only store a certain amount of energy, and during cloudy times, being connected to the grid is actually where the security is. You should install a backup generator to be prepared for these kinds of situations.

## ➤ Equipment for Off-Grid Systems

Typical off-grid solar systems require the following extra components:

- Solar Charge Controller
- Battery Bank
- DC Disconnect (additional)
- Off-Grid Inverter
- Backup Generator (optional)

### 1. Solar Charge Controller

Solar charge controllers are also known as charge regulators or just battery regulators. The last term is probably the best to describe what this device actually does: Solar battery chargers limit the rate of current being delivered to the battery bank and protect the batteries from overcharging.

**Good charge controllers are crucial for keeping the batteries healthy, which ensures the lifetime of a battery bank is maximized.** If you have a battery-based inverter, chances are that the charge controller is integrated.

## 2. Battery Bank

Without a battery bank (or a generator) it'll be lights out by sunset. A battery bank is essentially a group of batteries wired together.

## 3. DC Disconnect Switch

AC and DC safety disconnects are required for all solar systems. For off-grid solar systems, one additional DC disconnect is installed between the battery bank and the off-grid inverter. It is used to switch off the current flowing between these components. This is important for maintenance, troubleshooting and protection against electrical fires.

## 4. Off-Grid Inverter

There's no need for an inverter if you're only setting up solar panels for your boat, your RV, or something else that runs on DC current. You will need an inverter to convert DC to AC for all other electrical appliances.

**Off-grid inverters do not have to match phase with the utility sine wave as opposed to grid-tie inverters.** Electrical current flows from the solar panels through the solar charge controller and the bank battery bank before it is finally converted into AC by the off-grid-inverter.

## 5. Backup Generator

It takes a lot of money and big batteries to prepare for several consecutive days without the sun shining (or access to the grid). This is where backup generators come in.

In most cases, installing a backup generator that runs on diesel is a better choice than investing in an oversized battery bank that seldom gets to operate at its full potential. Generators can run on propane, petroleum, gasoline and many other fuel types.

Backup generators typically output AC, which can be sent through the inverter for direct use, or it can be converted into DC for battery storage.

## Hybrid Solar Systems

Hybrid solar systems combines the best from grid-tied and off-grid solar systems. These systems can either be described as off-grid solar with utility backup power, or grid-tied solar with extra battery storage.

If you own a grid-tied solar system and drive a vehicle that runs on electricity, you already kind of have a hybrid setup. The electrical vehicle is really just a battery with wheels.

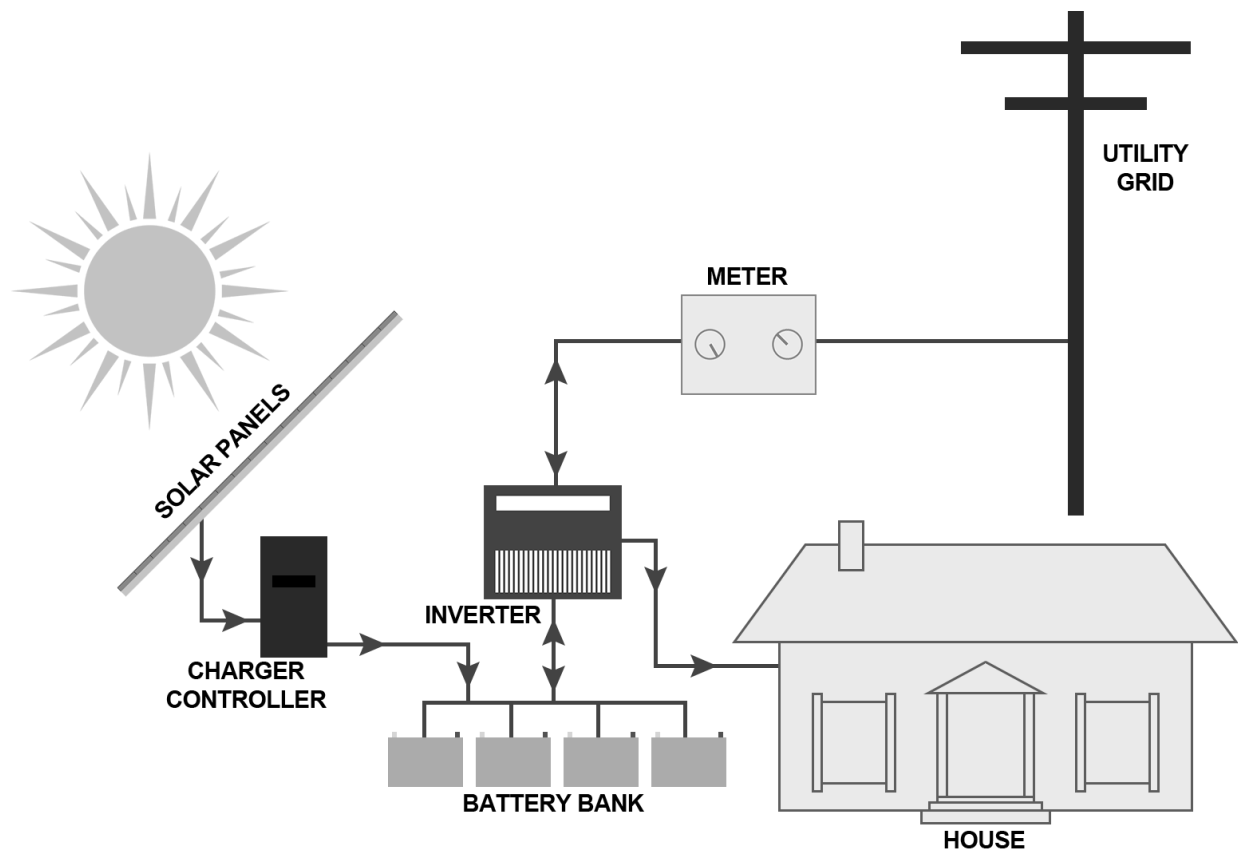

### ➤ Advantages of Hybrid Solar Systems

1. Less expensive than off-grid solar systems

**Hybrid solar systems are less expensive than off-grid solar systems.** You don't really need a backup generator, and the capacity of your battery bank can be downsized. Off-peak electricity from the utility company is cheaper than diesel.

## 2. Smart solar holds a lot of promise

**The introduction of hybrid solar systems has opened up for many interesting innovations.** New inverters let homeowners take advantage of changes in the utility electricity rates throughout the day.

Solar panels happen to output the most electrical power at noon – not long before the price of electricity peaks. Your home and electrical vehicle can be programmed to consume power during off-peak hours (or from your solar panels).

Consequently, you can temporarily store whatever excess electricity your solar panels in batteries, and put it on the utility grid when you are paid the most for every kWh.

**Smart solar holds a lot of promise. The concept will become increasingly important as we transition towards the smart grid in the coming years.**

### ➤ Equipment for Hybrid Solar Systems

Typical hybrid solar systems are based on the following additional components:

- Charge Controller
- Battery Bank
- DC Disconnect (additional)
- Battery-Based Grid-Tie Inverter
- Power Meter

#### 1. Battery-Based Grid-Tie Inverter

Hybrid solar systems utilize batter-based grid-tie inverters. These devices combine can draw electrical power to and from battery banks, as well as synchronize with the utility grid.

**The bottom line is this:** Right now, for the vast majority of homeowners, tapping the utility grid for electricity and energy storage is significantly cheaper and more practical than using battery banks and/or backup generators.

## Why a DC System is Not Feasible

Low voltage DC power as in solar arrays can be distributed without loss for only a FEW FEET. Medium and Long Distance DC transmission at low voltages is inefficient. The fool called T.A Edison tried to impose this useless DC system on us but the Genius Nikola Tesla invented the Polyphase AC Generation and Transmission System and gave us the World we are so conveniently living in today.

High Voltage DC transmission is an exception and also very lethal! It is used for Electric Locomotives and certain long distance power transmission. Such high voltage DC lines cannot be used for residential distribution as its highly lethal and can't be simply transformed to required voltage like AC.

And finally, most of the appliances in homes whether in villages or urban areas are designed to operate on AC not DC. All our present day electrical transmission and utilization infrastructure is compatible only with AC and I guess there is nothing wrong with it being so.

“The more number of steps in energy conversion, the lower and lower the yield of useful energy, and more expensive the entire infrastructure will be” .....we need something which is compact and affordable by at least middle class families.

The name seems catchy! Ok first of all there is NO BATTERY BANK involved in a Grid-Tied system. Here the Grid acts as the (virtual) Battery Bank.

So when the Grid is stopped or fails.....you have no power at all! Even though your panels can output power, the GTI is restricted from working and will not supply even a single watt of power until Grid comes back and it resynchronizes.

Solar Arrays at the best are a SECONDARY SOURCE of electricity who's OUTPUT FLUCTUATES with even the SLIGHTEST CHANGE of incoming SOLAR IRRADIATION. On the other hand battery banks and Grid are much more reliable PRIMARY SOURCES whose output will not fluctuate as much.

If you don't have a huge battery bank or the grid tie/synced operation, then the Solar Array output will fluctuate and none of your appliances will ever work PROPERLY.

Therefore a Grid Tied Inverter STOPS as soon as the Grid stops even though panels are outputting DC power. Grid tie/synced Inverters with Battery Backup have not yet been implemented.

## Different Types of Inverters

### ➤ Off-Grid Inverter

This is the traditional inverter type which has a solar charge controller charging a “LARGE BATTERY BANK” that supplies power to a DC-AC inverter which enables us to run AC loads. So there is an “INTERMEDIATE STEP” of solar to chemical energy conversion involved in this process. The batteries are always involved in the energy conversion process. This type of inverter works only as long as the batteries have some charge left in them. There is no connection to the GRID and this system goes dead once “Low Battery” is reached. The large battery bank (MOST EXPENSIVE PART OF THE OFF-GRID SYSTEM) is a necessary evil to ensure a steady/smooth output from the Inverter to the AC loads even under a significantly varying Solar Irradiation condition.

### ➤ On-Grid Inverter

This is the same as an off-grid inverter but a simple DPDT (Double Pole Double Throw) AC Power Relay is connected at Inverter output and as soon as “Low Battery” is reached and Inverter shuts down, the AC Loads are re-connected to the GRID. This way the LOADS have an uninterrupted supply of power and chances of total blackout is quite less.

### ➤ Grid Tied (Grid Synchronized) Inverter

Here comes the most interesting part of solar power harnessing to get usable 120/230VAC electric power. The Grid Tied Inverter has its OUTPUT synchronized to the FREQUENCY (exactly same), PHASE (exactly same) and VOLTAGE (slightly higher for feeding power into GRID and also powering the LOAD) of the GRID. The output of the Inverter and Grid Supply are literally paralleled and connected to the Load.

“WHAT IS THE BEST BENEFIT WE OBTAIN FROM SUCH AN ARRANGEMENT?”

Let me cite an example to you. Say we have a 4.5KiloWatt Peak Solar Array which is connected to a Grid Synchronized Inverter. Let’s assume its 7:30AM in the morning and you are using a LOAD

of 1.8KiloWatt. Also let's assume that the Solar Array is able to provide just about 600Watts of power at the time of day. Without a large battery bank as in an off-grid system, we cannot simply run the LOAD on PV alone isn't it? But a large battery bank is pretty expensive in terms of initial cost and maintenance/replacement batteries cost. So this Grid Synchronized Inverter eliminates the large battery bank and the associated "Prohibitive Cost" and poor "Solar to Electrical Energy Conversion Ratio" of the off-grid system.

It also does a great job by letting us use that little amount of 600Watts of PV power to partially run our 1.8KiloWatt Load, the rest being "SUPPLEMENTED" by the Grid. As the Sun moves across the sky and more PV power is generated, the lesser utilization of the Grid to power that 1.8KiloWatt Load.

What I am trying to say is that no matter how much little the power output of Solar Array is, WE CAN BE SURE that it is EFFICIENTLY HARNESSSED and USED to the MAXIMUM EXTENT. Since the GRID is an Infinite Voltage Source, the LOAD will never experience a blip or brown-out due to the GRID SYNCING operational topology. You wouldn't want you LOADS to be blinking/flickering with just a slight change in Solar Irradiation, isn't it?

But there is one problem with Grid Synced Inverters, which is:

As per UL1741 directive, Grid Synced Inverters must shut down within 100millisecs of Grid Failure or disconnection at transformer. This is a safety requirement for maintenance and troubleshooting personnel. This is an important PROTOCOL to follow but if a Grid Synced Inverter stops supplying power to your Loads when Grid fails or is stopped, it wouldn't be a great topology to use, isn't it? So we have to find a workaround (which is what I've planned and have a decent idea in my mind) to be able to follow the PROTOCOL as well as keep the Loads powered.

## Cells, Modules and Arrays

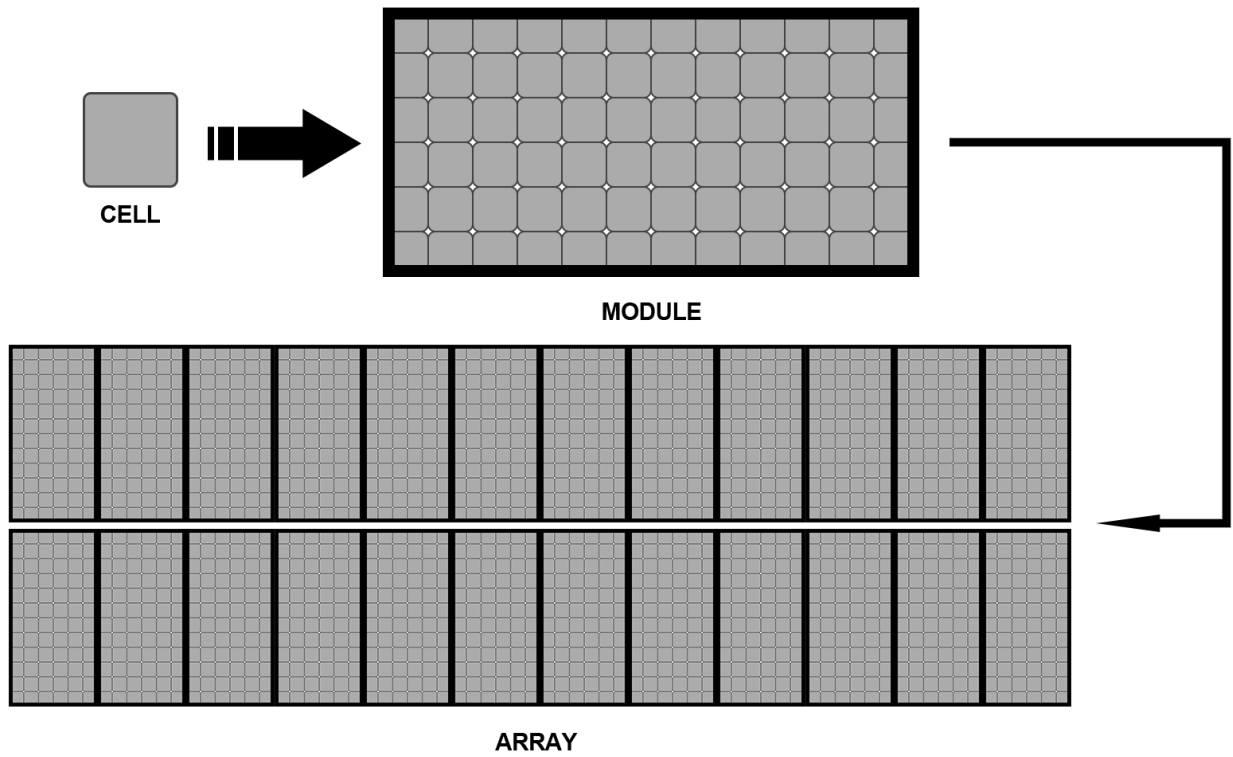

### ➤ Solar Cells

Solar Cells are semiconductor devices that convert sunlight to dc electricity.

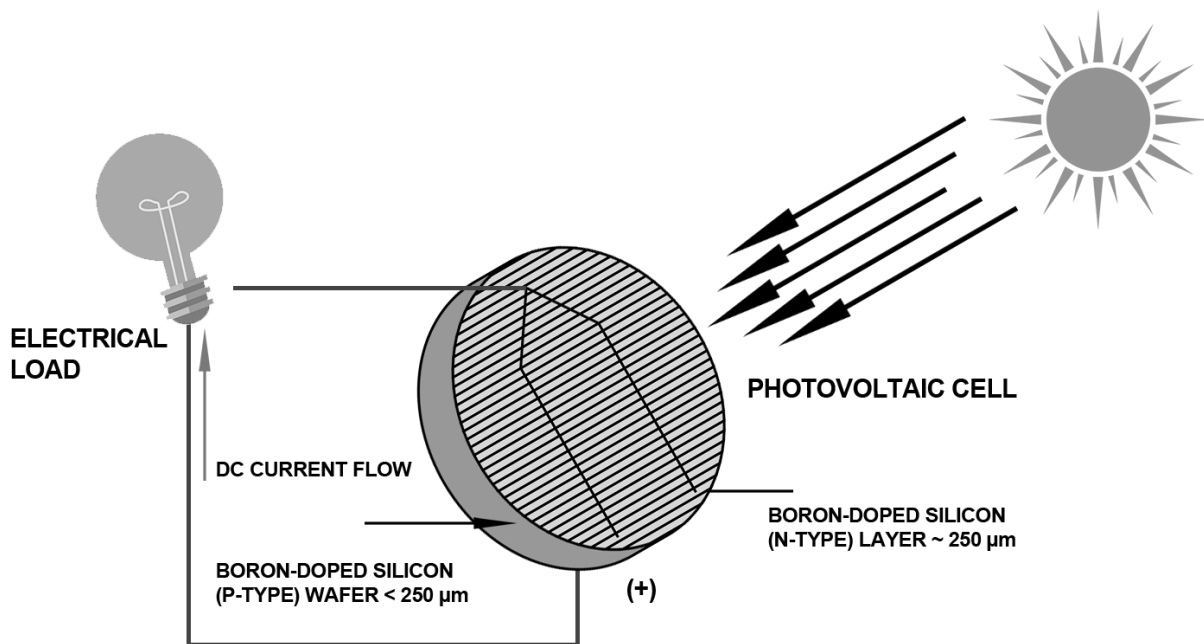

## ➤ The Photovoltaic Effect

1. The photovoltaic effect is the process of creating a voltage across charged materials that are exposed to electromagnetic radiation.
2. Photons in sunlight impart their energy to excess charge carriers (electrons and holes) allowing them to freely move about the material.
3. Charge opposition between the two materials creates an electrical field that provides momentum and direction to the free charge carriers, resulting in the flow of electrical current flow when the cell is connected to a load.

## ➤ Silicon Solar Cells

1. Silicon solar cells produce about 0.5 to 0.6 volt independent of cell area, depending on temperature.
2. The current output of a solar cell depends primarily on the cell area, its efficiency, and the incident solar radiation.
3. Modern silicon solar cells are up to 8 inches in diameter and produce up to 4 watts and 8 amps under full sunlight.

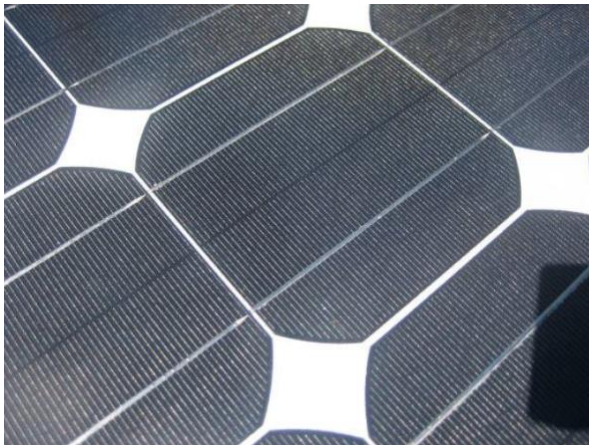

**Mono crystalline Cell**

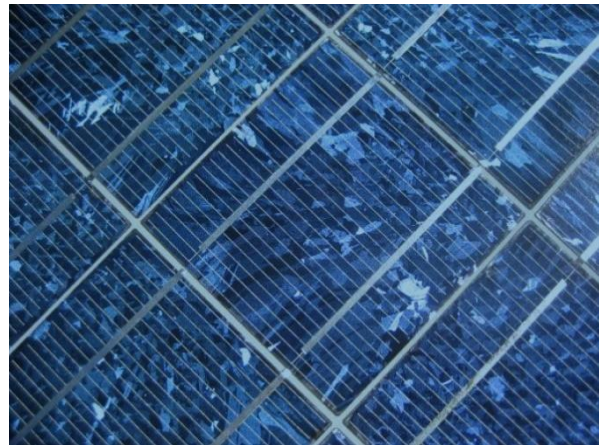

**Polycrystalline Cell**

## ➤ Crystalline Silicon Wafer Production

1. The following processes are commonly used to create P-type silicon wafers:
  - The Czochralski method produces a single or monocrystalline wafer.
  - The cast ingot method produces a multigrain or polycrystalline wafer.
  - The ribbon method produces polycrystalline wafers by drawing molten silicon between dies in a continuous process.
2. Wafer are additionally processed to produce a complete solar cell.

## ➤ Monocrystalline Wafer Production: Czochralski Method

1. Single crystal or monocrystalline silicon wafers are grown in the form of a cylindrical ingot, creating a perfect crystal.

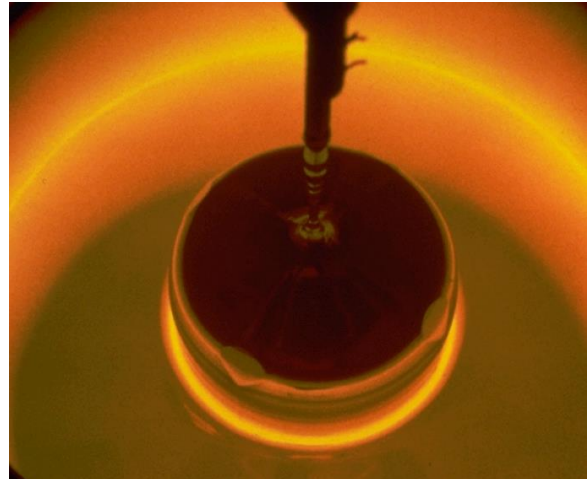

2. A seed crystal is inserted into molten polysilicon doped with boron, rotated and drawn upward allowing the P-type silicon material to cool into a cylindrical ingot.



## ➤ Polycrystalline Silicon Wafer Production

1. Polycrystalline or multi-crystalline silicon wafer are cast, forming a block-shaped ingot that has many crystals.
2. Molten polysilicon doped with boron is poured into a rectangular crucible, and slowly cooled at controlled rate.
3. Polycrystalline wafers are also made using the ribbon method.

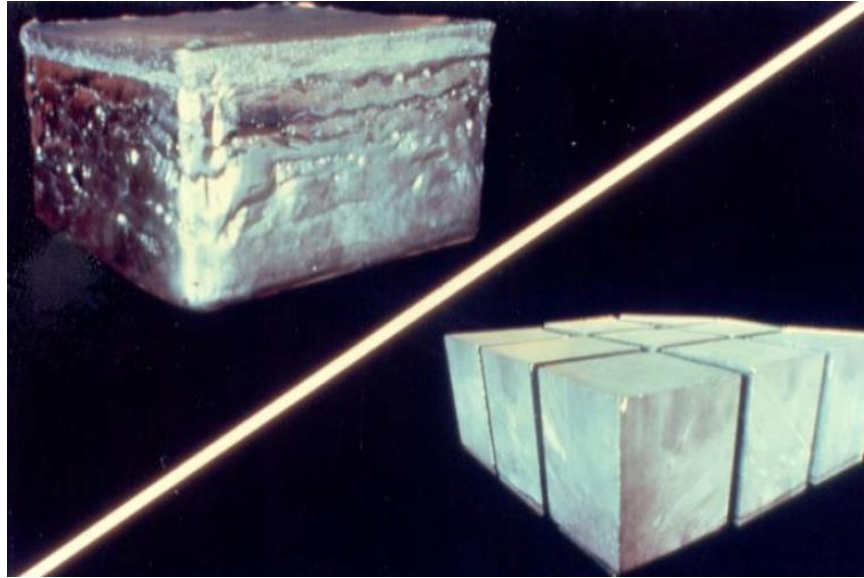

**Cast Ingot Method**

## ➤ Solar Cell Manufacturing

Once a P-type silicon ingot is produced, a number of additional steps are required to create an actual solar cell.

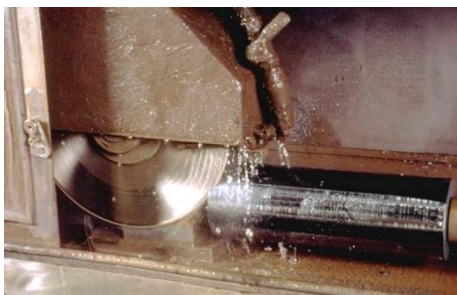

**Cropping**

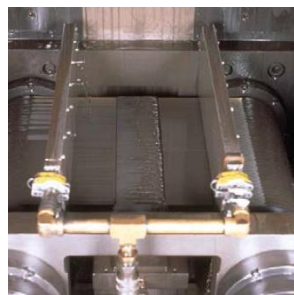

**Sawing**



**Phosphorous diffusion**



**Screen printing**

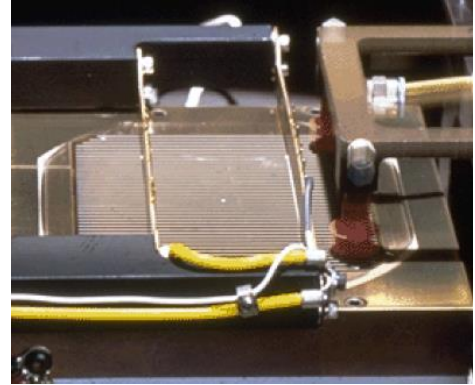

**Electrical testing**

### ➤ Flat-Plate PV Modules

Flat-plate PV modules respond to both direct and diffuse solar radiation, and are the smallest field installable generating unit.



**Single (mono) crystalline**

**Polycrystalline**

## ➤ Typical PV Module Construction

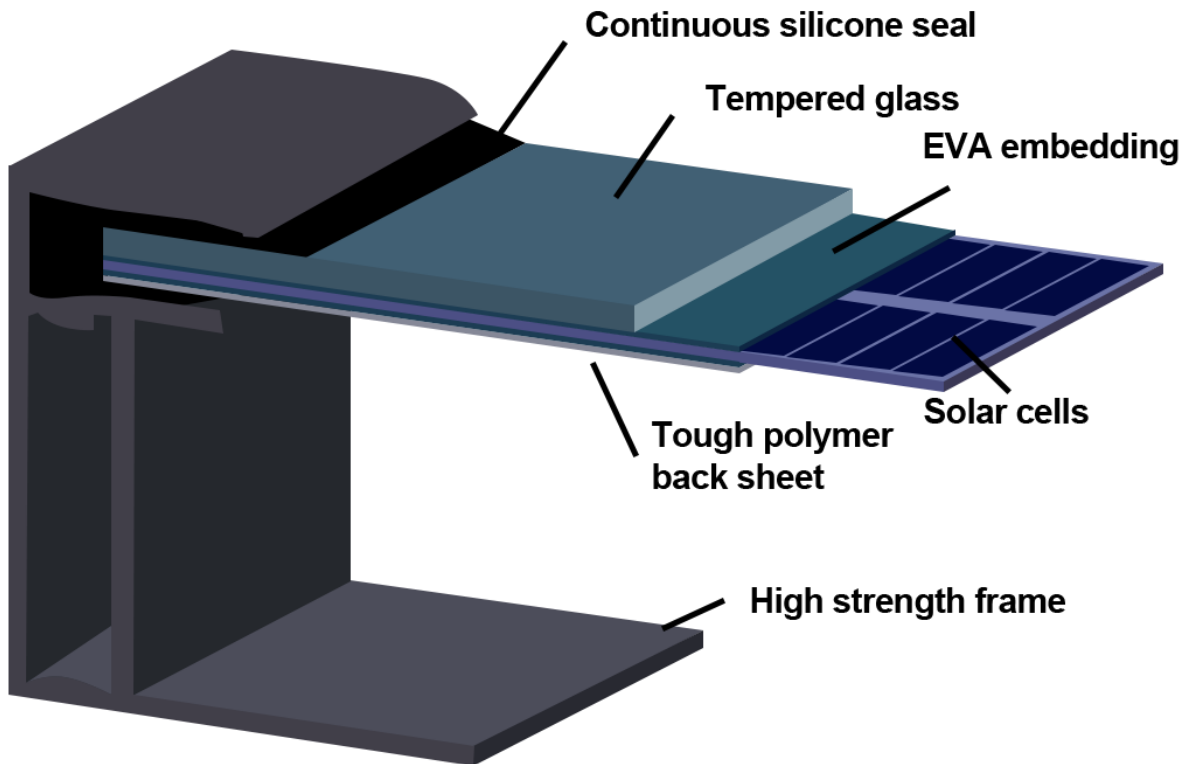

## ➤ Emerging PV Module Technologies

1. Thick wafer silicon P-N junction solar cells are considered first generation PV devices.
2. Second generation devices are thin-film devices including:
  - Amorphous silicon (a-Si)
  - Cadmium Telluride (CdTe)
  - Copper indium gallium selenide (CIS or CIGS)
3. Other advanced PV module designs include:
  - Concentrating PV modules
  - AC modules
  - Polymer and organic solar cells

## ➤ Thin-Film PV Modules

1. Thin-film PV modules are produced by depositing ultra-thin layers of semiconductor materials on a flexible or rigid substrate.



2. Thin-film modules have significant potential for cost and weight reduction.

3. Disadvantages include lower efficiencies and higher degradation rates than crystalline silicon modules.

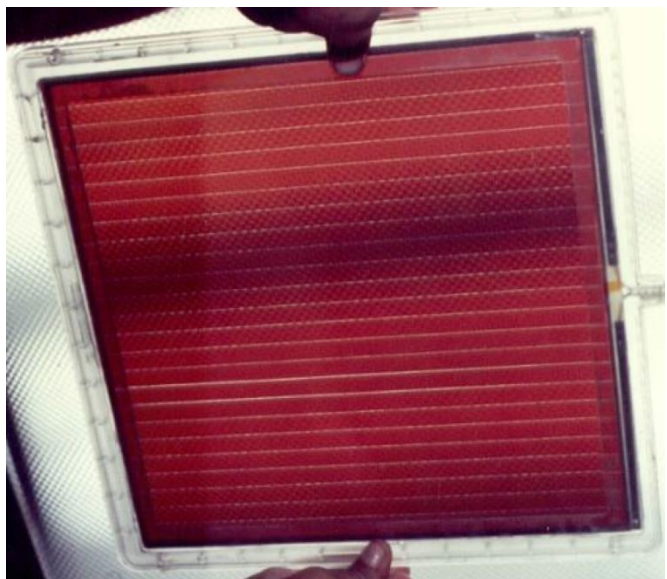

## ➤ Concentrating PV Modules

1. Use optics to focus sunlight on solar cells up to 200-500 X.
2. Employ advanced multifunction solar cells approaching efficiencies of up to 40%.
3. Utilize only direct component of total global solar radiation, and employ two-axis sun tracking.
4. Design challenges include managing high temperatures and high DC currents.

## ➤ Ac Modules and Micro-Inverters

1. Alternating-current (AC) modules are an integrated PV module and inverter product intended for installation as a single unit.
2. AC modules do not have any field-installed DC wiring.
3. Micro-inverters are separate module level inverters are separates intended for field installation.

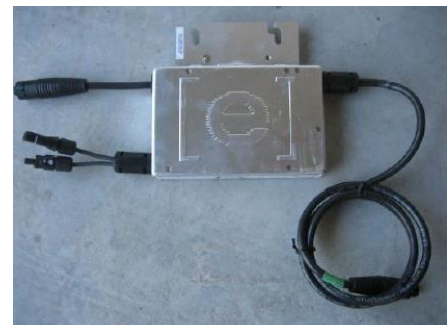
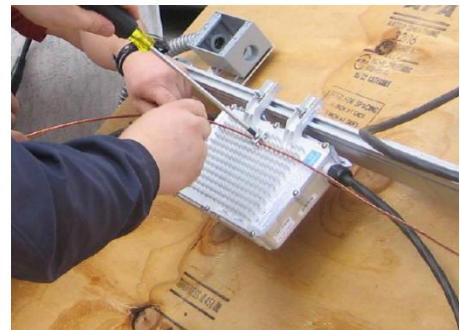

## ➤ Leading Manufacturers of PC Cells AND Modules

1. BP Solar
2. First Solar
3. JA Solar
4. Kyocera
5. Mitsubishi
6. Motech
7. Q-Cells
8. Sanyo
9. Schott Solar
10. Sharp Solar
11. SolarWorld
12. SunPower
13. Suntech
14. Trina
15. Yingli

## ➤ Current-Voltage (I-V) Characteristics

1. The electrical performance of a PV device is given by its current-voltage (I-V) curve.
2. Represents an infinite number of I-V operating points.
3. Varies with solar radiation and device temperature.

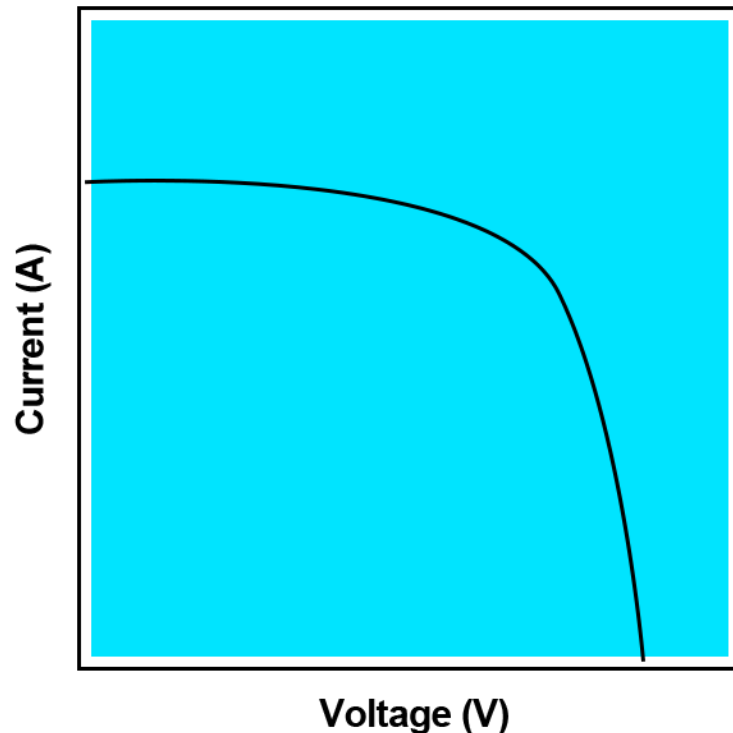

## ➤ Key I-V Parameters

PV device performance is specified by the following I-V parameters at a given temperature and solar irradiance condition:

- Open-circuit voltage ( $V_{oc}$ )
- Short-circuit current ( $I_{sc}$ )
- Maximum power point ( $P_{mp}$ )
- Maximum power voltage ( $V_{mp}$ )
- Maximum power current ( $I_{mp}$ )

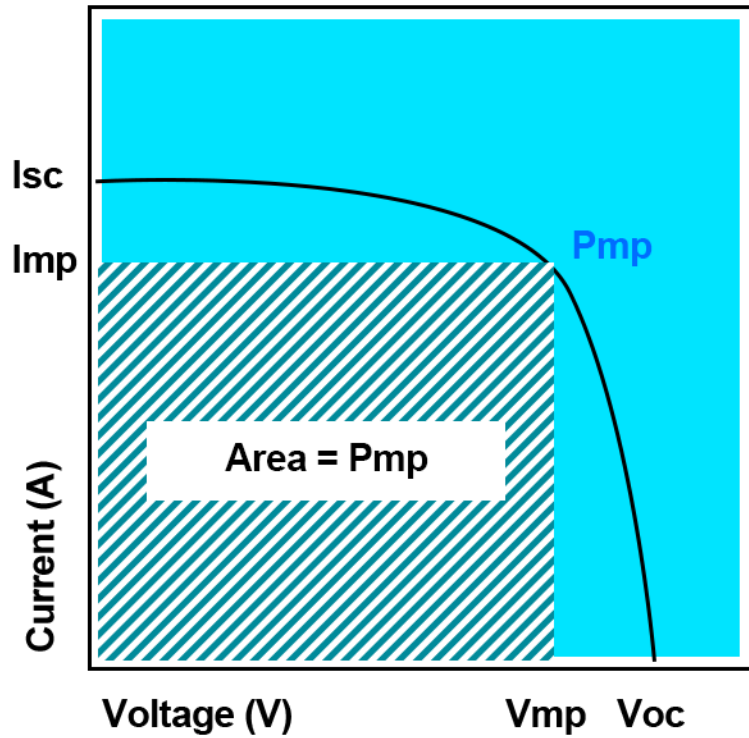

## ➤ Power vs. Voltage Curve

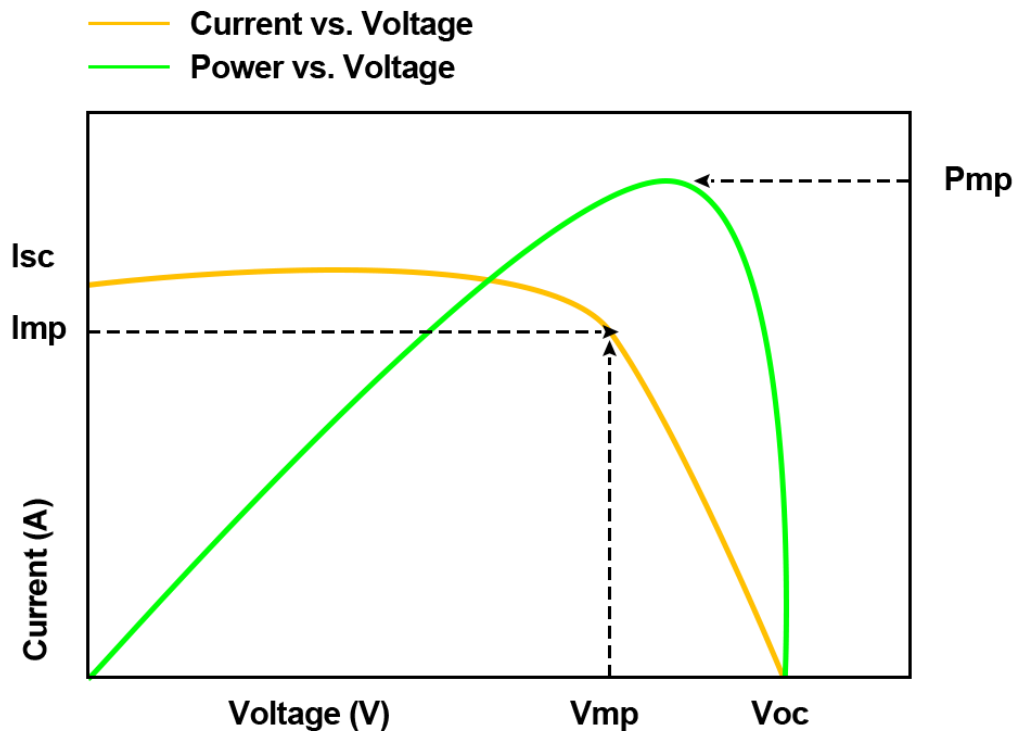

## ➤ PV Module Rating Conditions

The electrical performance of PV modules is rated at Standard Test Conditions (STC):

- Irradiance: 1.000 W/m<sup>2</sup>, AM 1.5
- Cell temperature: 25°C



SW 245		
Maximum power	$P_{max}$	245 Wp
Open circuit voltage	$V_o$	37.7 V
Maximum power point voltage	$V_{mpp}$	30.8 V
Short-circuit current	$I_{sc}$	8.25 A
Maximum power point current	$I_{mpp}$	7.96 A

## ➤ Fill Factor

Fill factor (FF) is an indicator of the quality of a solar cell.

- $FF = (V_{mp} \times I_{mp}) / (V_{oc} \times I_{sc}) = P_{mp} / (V_{oc} \times I_{sc})$

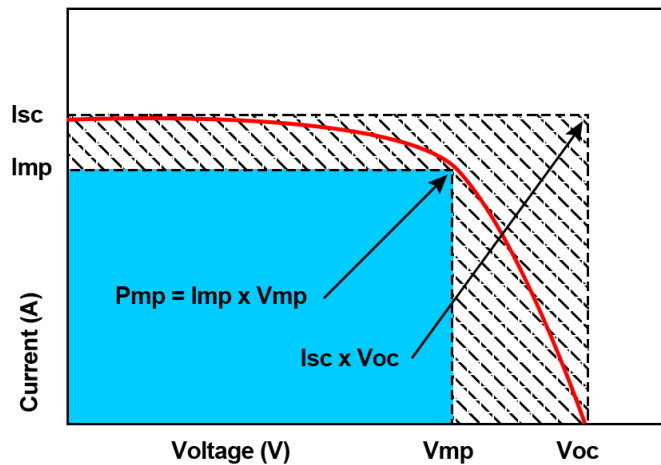

## ➤ Efficiency

1. Efficiency of a PV device is the ratio of the electrical power output and the solar irradiance input over the device area, expressed as a percentage:

$$\eta = \frac{P_{mp}}{E \times A}$$

where

$\eta$  = efficiency

$P_{mp}$  = maximum power rating (W)

$E$  = solar irradiance (W/m<sup>2</sup>)

$A$  = surface area (m<sup>2</sup>)

2. Example:

- What is the efficiency for a PV module that has a surface area of 1.4 m<sup>2</sup>, and produces 200 W maximum power when exposed to 1000 W/m<sup>2</sup> solar irradiance?

$$\eta = \frac{P_{mp}}{E \times A}$$

$$\eta = \frac{200 \text{ W}}{(1000 \text{ W/m}^2 \times 1.4 \text{ m}^2)}$$

$$\eta = 0.143 = 14.3\%$$

## ➤ Response to Electrical Load

1. The electrical load connected to a PV device determines its operating Point.
  - If a battery is connected to a PV device, the battery voltage sets the operating voltage for that PV device.
  - In a grid-connected PV system, the inverter loads the PV array at its maximum power point.
2. From Ohm's Law, the electrical load resistance that operates a PV device at its maximum power point is equal to  $V_{mp}/I_{mp}$  (ohms).

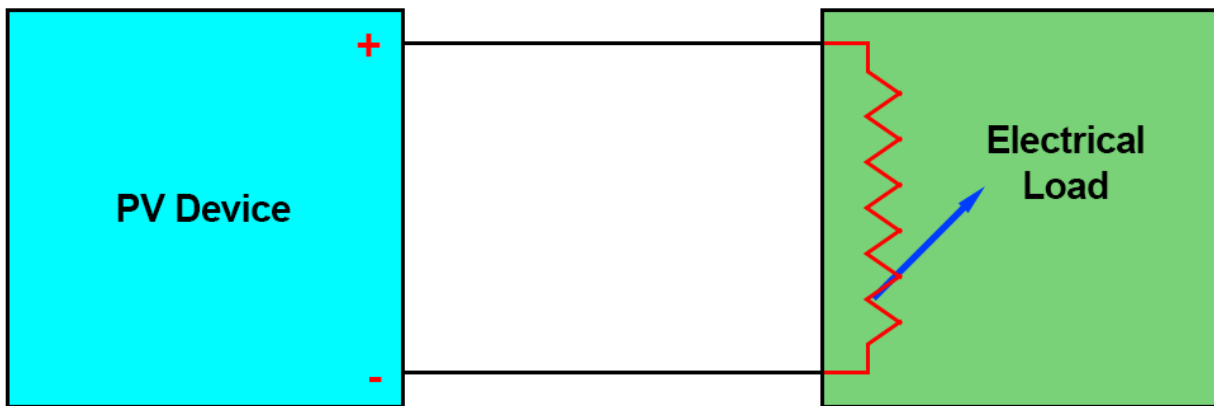

## ➤ Operating Point

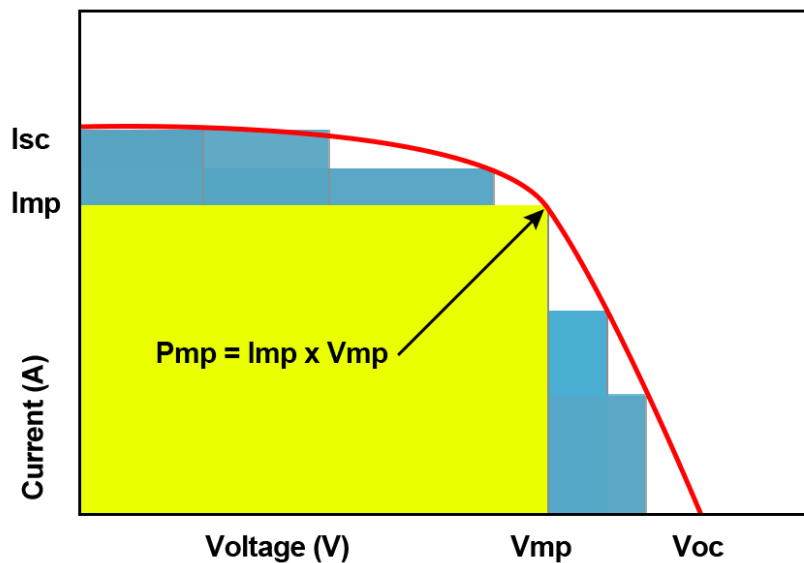

## ➤ PV Modules for Battery Charging

PV module maximum power voltage must be higher than battery voltage at highest operating temperature.

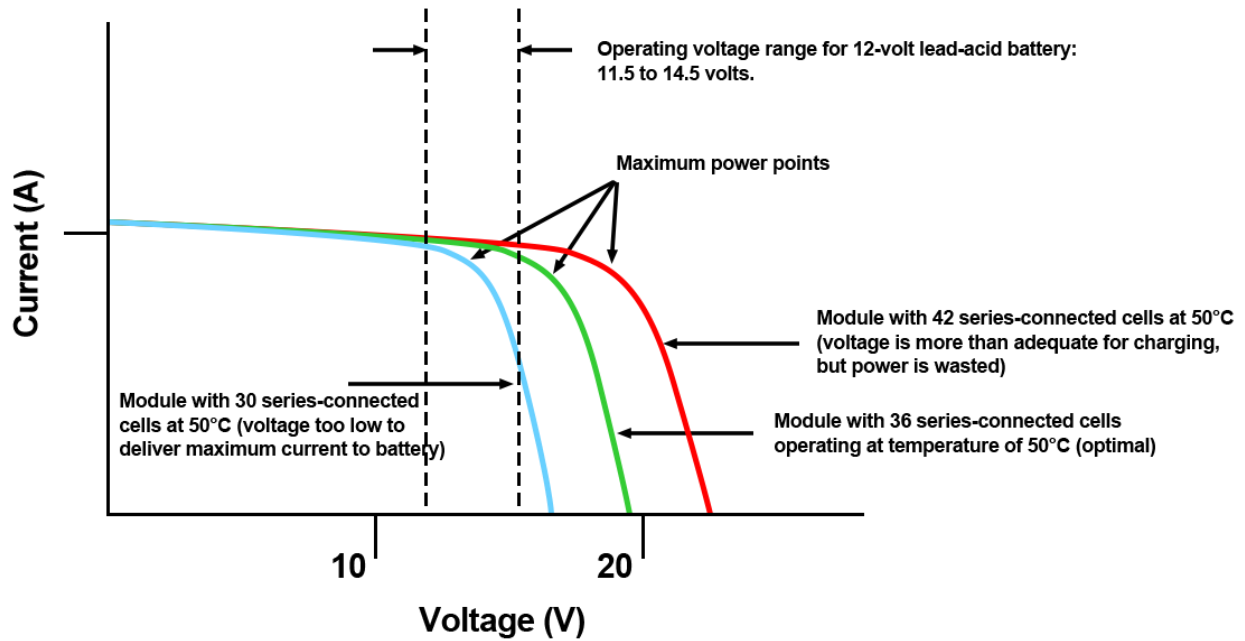

## ➤ Effect of Electrical Load on Operating Point

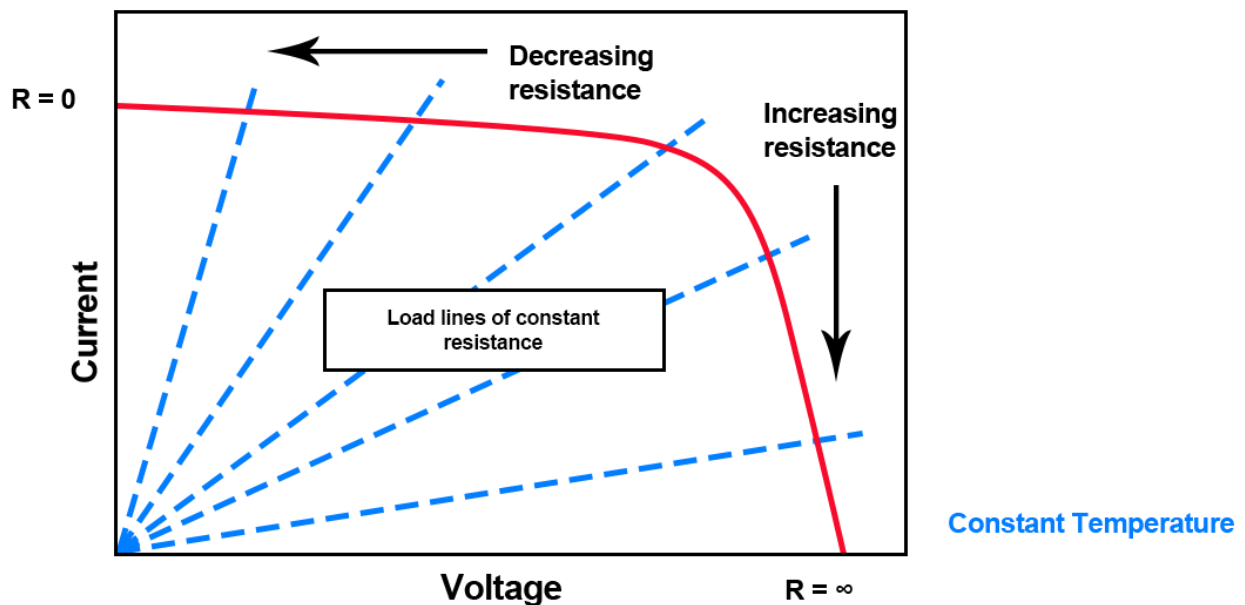

➤ I-V Measurement Methods

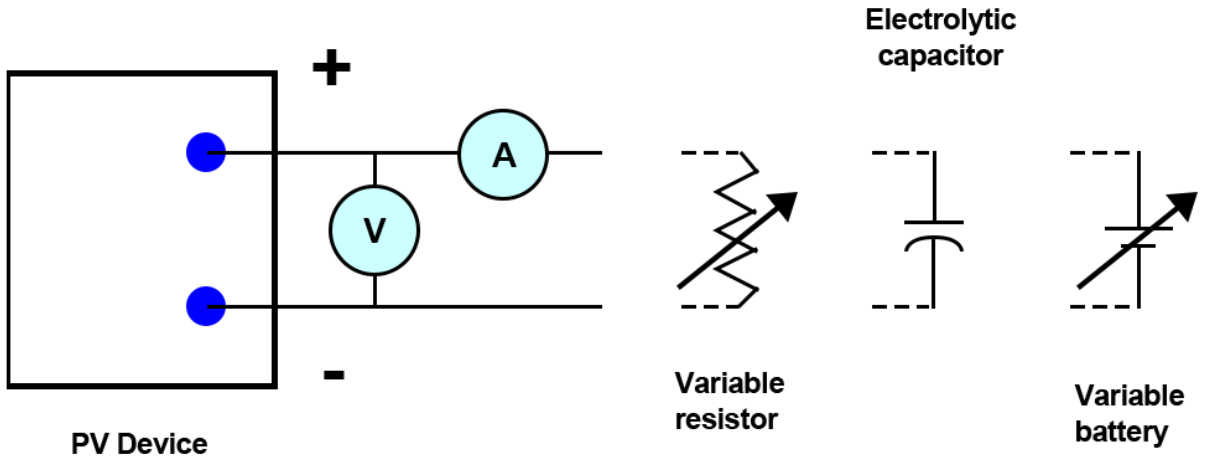

➤ Solmetric PVA-600 PV Analyzer



➤ Raydec DS-100 IV Curve Tracer

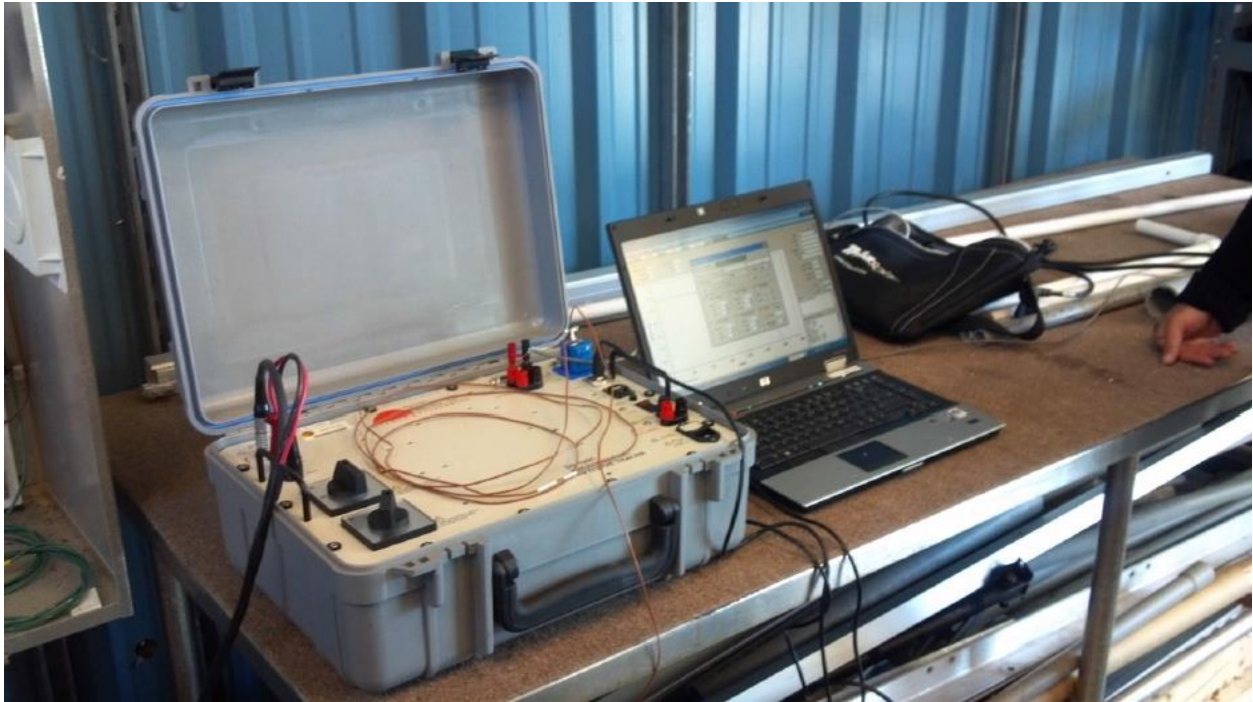

➤ Spire 4600 SLP Flash Simulator

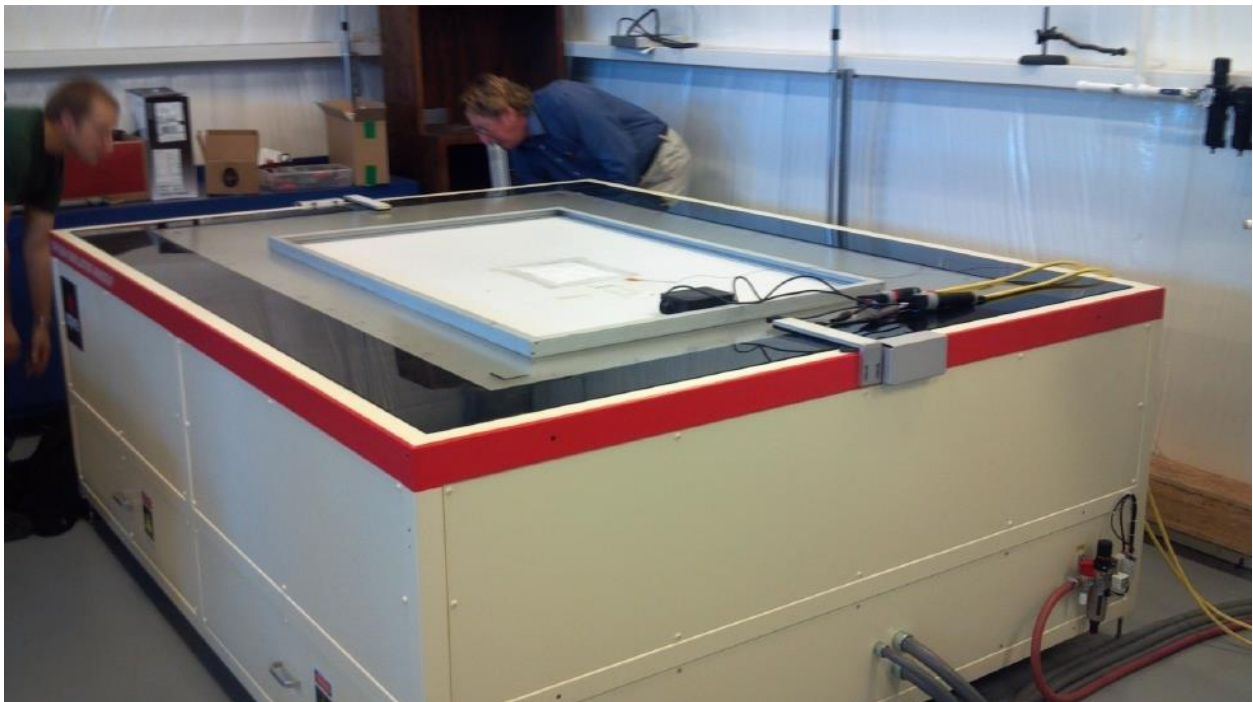

## ➤ Response to Electrical Load: Example

1. The maximum power voltage ( $V_{mp}$ ) and maximum power current ( $I_{mp}$ ) for a PV module are 35.8 volts and 4.89 amps, respectively. What is the maximum power and load resistance required to operate at maximum power?
2. The maximum power is calculated by the product of the maximum power voltage and maximum power current: 35.8 volts x 4.89 amps = 175 wats
3. From Ohm's Law, resistance is equal to the voltage divided by the current: 35.8 volts / 4.89 amps = 7.32 ohms

## ➤ Solar Cell Equivalent Circuit

A solar cell equivalent circuit consists of a current source in parallel with a diode and shunt resistance, connected to a series resistance.

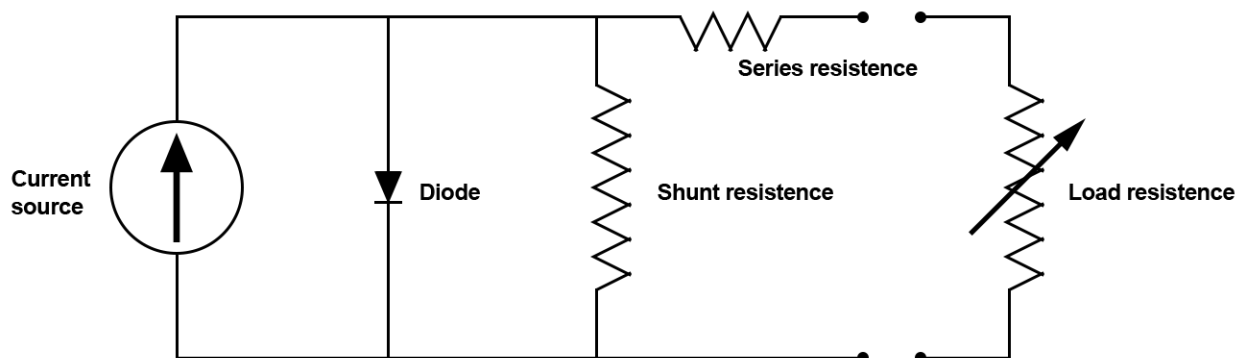

## ➤ Series Resistance

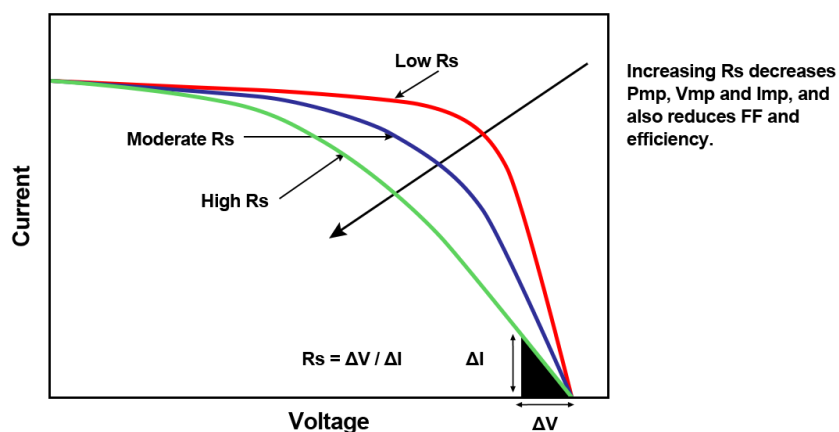

➤ Shunt Resistance

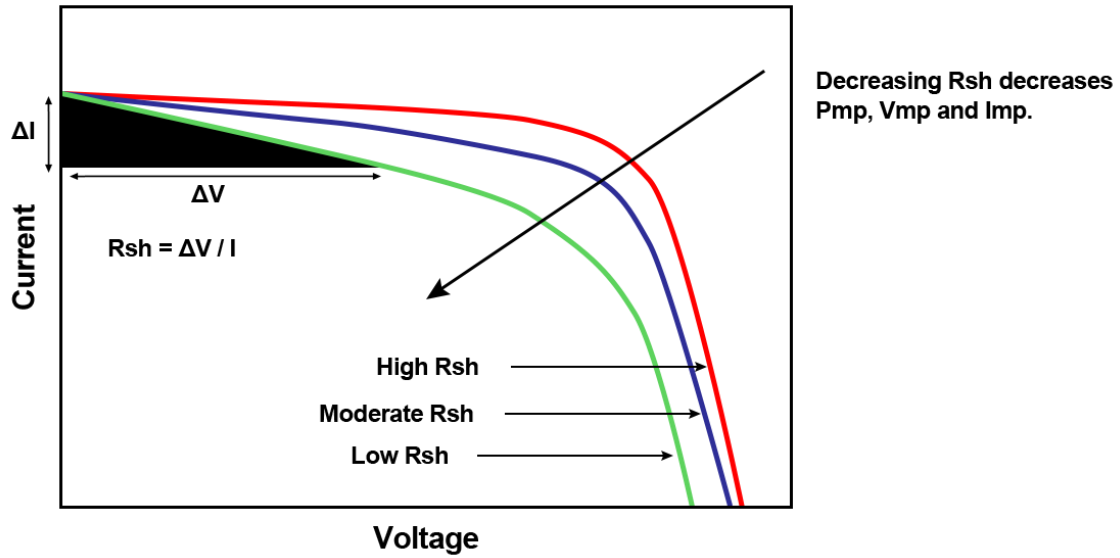

➤ Response to Solar Irradiance

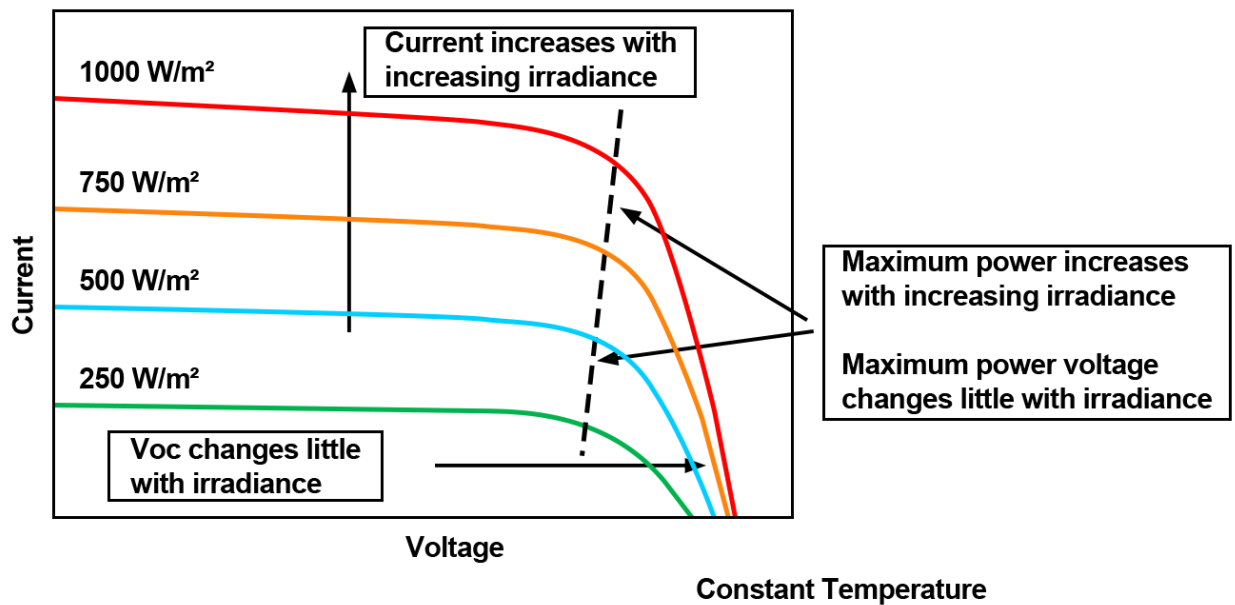

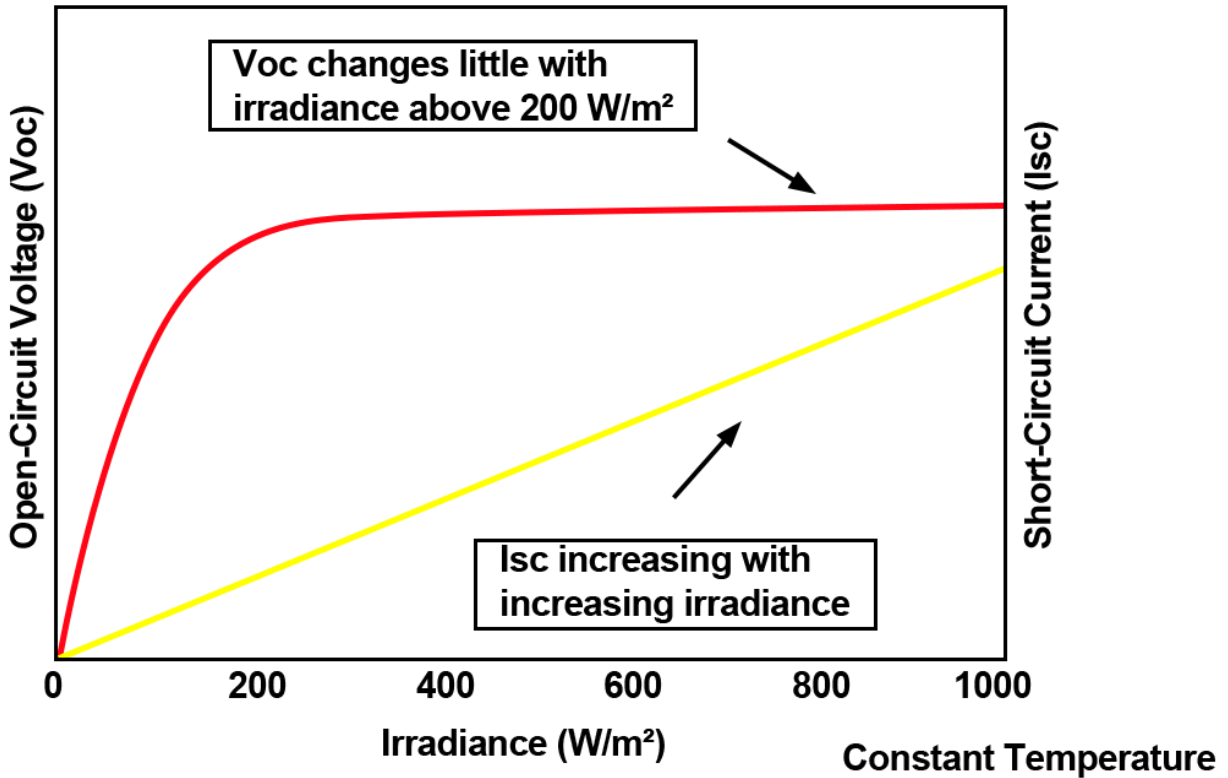

1. The power and current output of a PV device are proportional to the solar irradiance:

$$\frac{E_2}{E_1} = \frac{I_2}{I_1} = \frac{P_2}{P_1}$$

2. Example: A PV module produces 200 watts maximum power at 1000 W/m². Assuming constant temperature, the maximum power output at an irradiance level of 600 W/m² would be:

$$P_2 = \frac{E_2}{E_1} \times P_1 = \frac{600}{1000} \times 200 = 120 \text{ W}$$

## ➤ Response to Temperature

For crystalline silicon PV devices, increasing cell temperature results in a decrease in voltage and power, and a small increase in current.

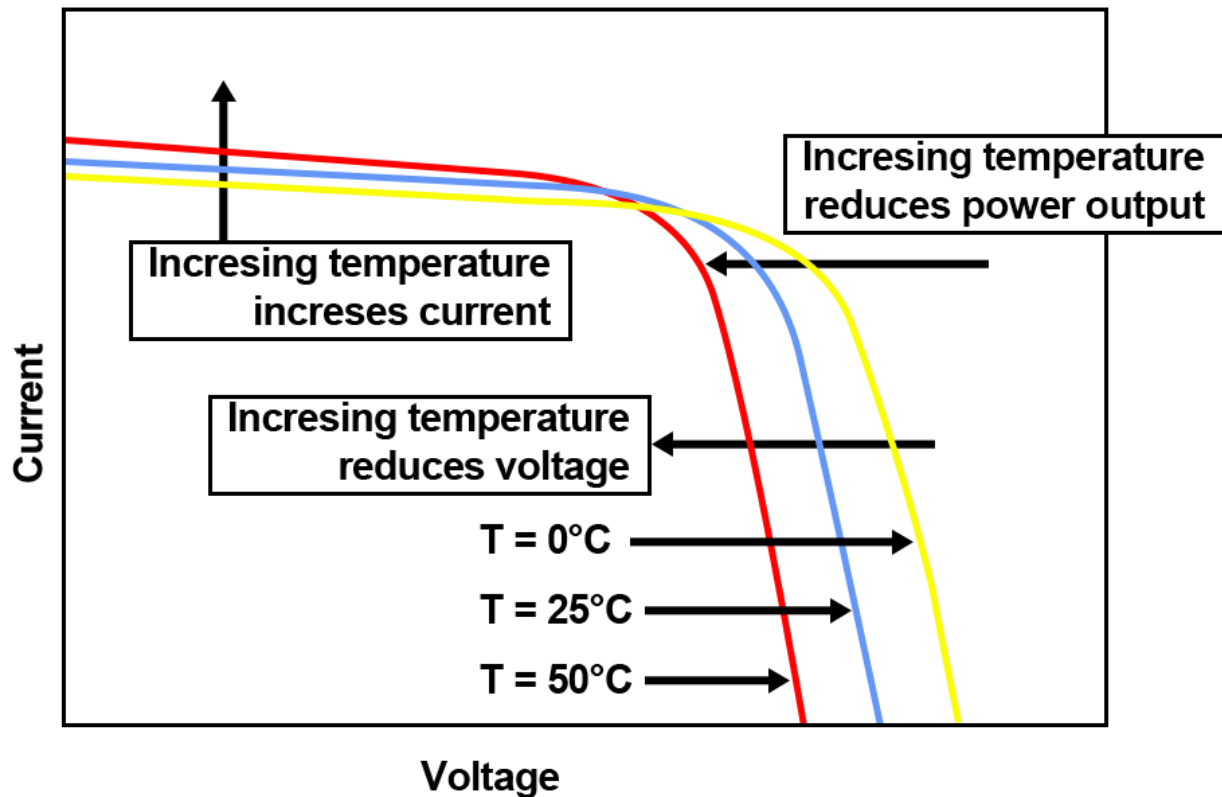

## ➤ Temperature-Rise Coefficient

1. The temperature-rise coefficient relates the temperature of a given PV array to the ambient air temperature and solar irradiance:

$$T_{cell} = T_{amb} + (C_{T-rise} \times E)$$

where

$$T_{cell} = \text{cell temperature } (^{\circ}\text{C})$$

$$T_{amb} = \text{ambient air temperature } (^{\circ}\text{C})$$

$$C_{T-rise} = \text{temperature-rise coefficient } (^{\circ}\text{C}/\text{kW}/\text{m}^2)$$

2. At peak sun, the difference between PV array and ambient air temperature can vary from 20 to 40°C, depending on the array mounting system design.

## ➤ Temperature Coefficient

1. Temperature coefficient relate the effects of changing PV cell temperature on voltage, current and power.
2. Percentage change coefficients are commonly used to translate voltage, current and power from one temperature condition to another temperature.
3. For crystalline silicon PV, percentage change temperature coefficients are approximately:
  - $C_V = -0.4\%/^{\circ}\text{C}$  (voltage decreases 1% for 2.5°C increase in temperature)
  - $C_I = +0.04\%/^{\circ}\text{C}$  (power increases 1% for 2.5°C increase in temperature)
  - $C_P = -0.45\%/^{\circ}\text{C}$  (power decreases 1% for 2.2°C increase in temperature)
4. Since the temperature coefficient for currents is an order of magnitude less than for voltage or power, the effects of temperature on current are not usually considered in system design.

## ➤ Temperature Coefficient

$$V_{trans} = V_{ref} + [V_{ref} \times C_V \times (T_{cell} - T_{ref})]$$

$$P_{trans} = P_{ref} + [P_{ref} \times C_P \times (T_{cell} - T_{ref})]$$

*where*

$V_{trans}$  = translated voltage at  $T_{cell}$  (V)

$V_{ref}$  = reference voltage at  $T_{ref}$  (V)

$P_{trans}$  = translated power at  $T_{cell}$  (W)

$P_{ref}$  = reference power at  $T_{ref}$  (W)

$C_V$  = voltage-temperature coefficient (% per °C)

$C_P$  = power-temperature coefficient (% per °C)

$T_{cell}$  = cell temperature (°C)

$T_{ref}$  = reference temperature (°C)

## ➤ Response to Temperature: Example 1

1. A 72-cell crystalline silicon PV module has a rated open-circuit voltage of 44.4 V at 25°C, and a voltage-temperature coefficient of -0.33 %/°C. What would the open-circuit voltage be at a cell temperature of 60°C?

$$V_{trans} = V_{ref} + [V_{ref} \times C_V \times (T_{cell} - T_{ref})]$$

$$V_{trans} = 44.4 \text{ V} + [44.4 \text{ V} \times -0.0033/^\circ\text{C} \times (60-25)^\circ\text{C}]$$

$$V_{trans} = 44.4 \text{ V} - 5.19 \text{ V} = 39.2 \text{ V}$$

2. If the same PV module operates at -10°C (35°C lower the reference temperature), the translated voltage is:

$$V_{trans} = 44.4 \text{ V} + [44.4 \text{ V} \times -0.0033/^\circ\text{C} \times (-10 - 25)^\circ\text{C}]$$

$$V_{trans} = 44.4 \text{ V} + 5.19 \text{ V} = 49.6 \text{ V}$$

## ➤ Response to Temperature: Example 2

1. A crystalline silicon PV array has a power-temperature coefficient of -0.45 %/°C and rated maximum power output of 50kW at 25°C and solar irradiance of 1000W/m<sup>2</sup>. What would the array maximum power be at a cell temperature of 50°C?

$$P_{trans} = P_{ref} + [P_{ref} \times C_P \times (T_{cell} - T_{ref})]$$

$$P_{trans} = 50 \text{ kW} + [50 \text{ kW} \times -0.0045/^\circ\text{C} \times (50-25)^\circ\text{C}]$$

$$P_{trans} = 50 \text{ kW} - 5.6 \text{ kW} = 44.4 \text{ kW}$$

2. If the same PV module operates at 0°C (25°C lower than the reference temperature of 25°C), the translated power is:

$$P_{trans} = 50 \text{ kW} + [50 \text{ kW} \times -0.0045/^\circ\text{C} \times (0 - 25)^\circ\text{C}]$$

$$P_{trans} = 50 \text{ kW} + 5.6 \text{ kW} = 55.6 \text{ kW}$$

## ➤ Building PV Arrays

1. PV modules are connected electrically in series to build voltage output.
2. Series string of PV modules are connected in parallel to build current and power output.

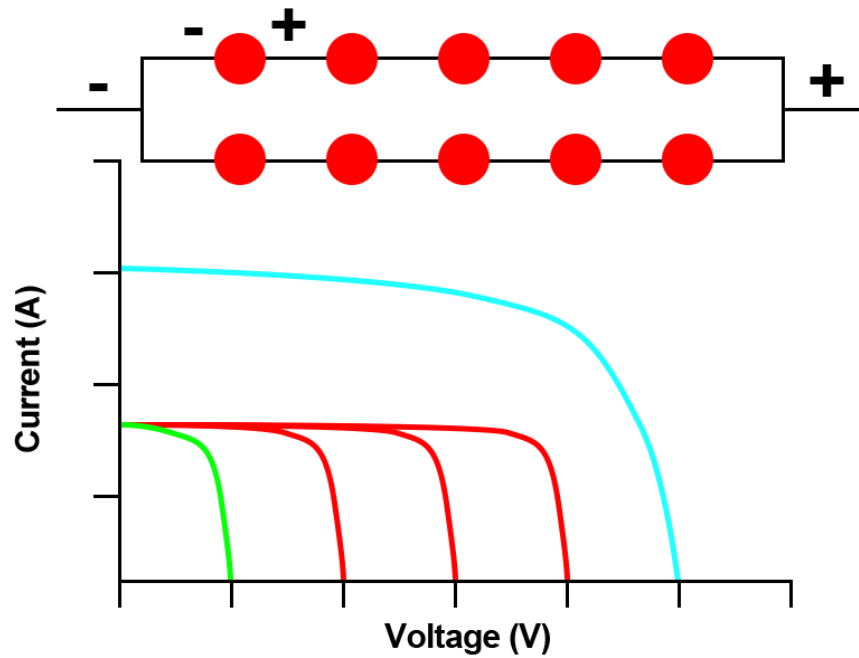

## ➤ Monopole and Bipolar PV Arrays

1. Monopole PV arrays consists of two output circuit conductors.
2. Bipolar PV arrays combine two monopole arrays with a center tap.

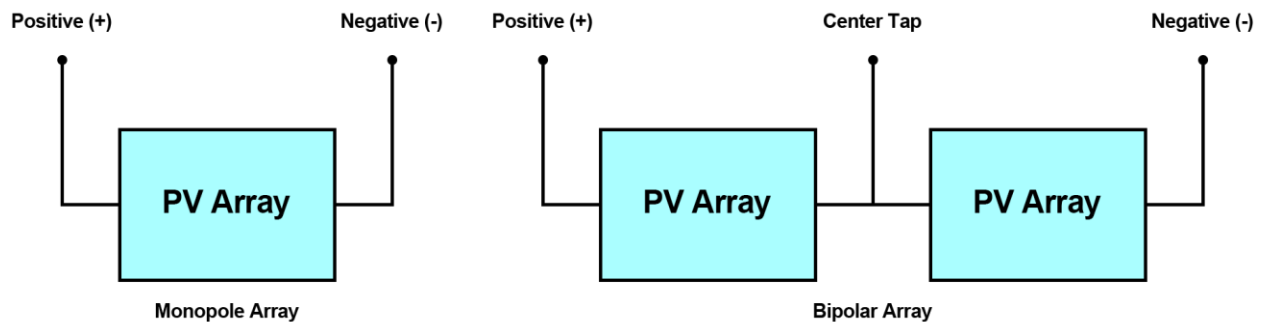



➤ Dissimilar PV Devices in Series

1. When dissimilar PV devices are connected in series, the voltages still add, but the current is limited by the lowest current output device in series.
2. Not acceptable.

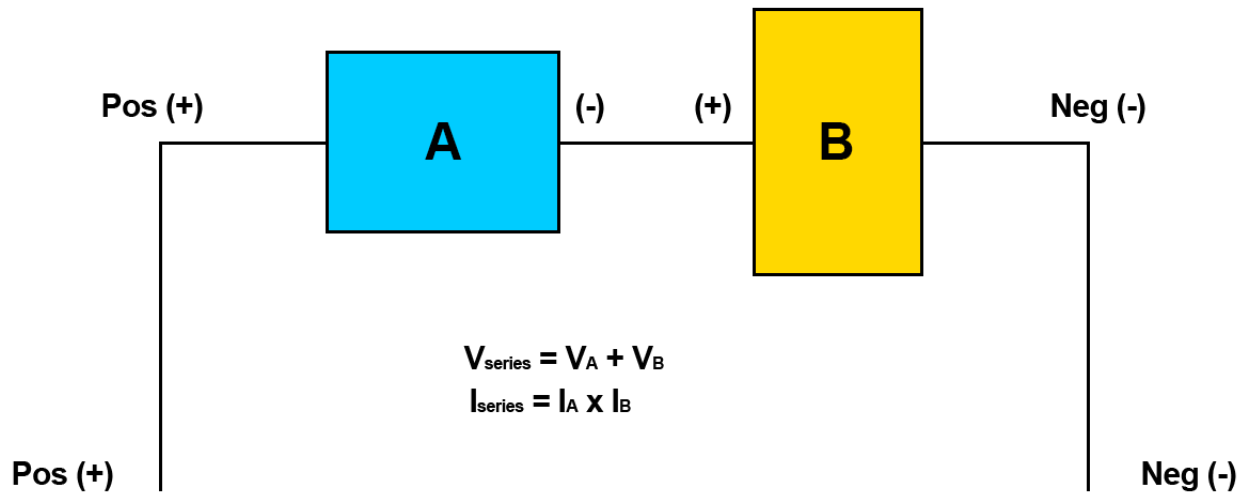

➤ Connecting PV Devices in Parallel

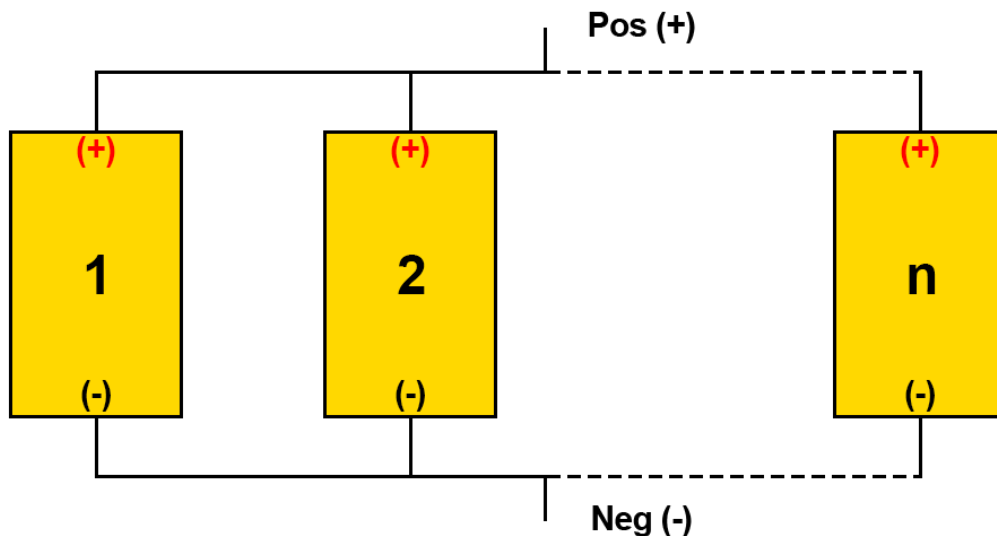

**For PV devices in parallel:**

$V_{parallel} = V_1 = V_2 \dots\dots\dots = V_n$  (for similar device)

$V_{parallel} = (V_1 + V_2 \dots\dots\dots + V_n) / n$

$I_{parallel} = I_1 + I_2 \dots\dots\dots + I_n$

➤ I-V Curves for Similar PV Devices in Parallel

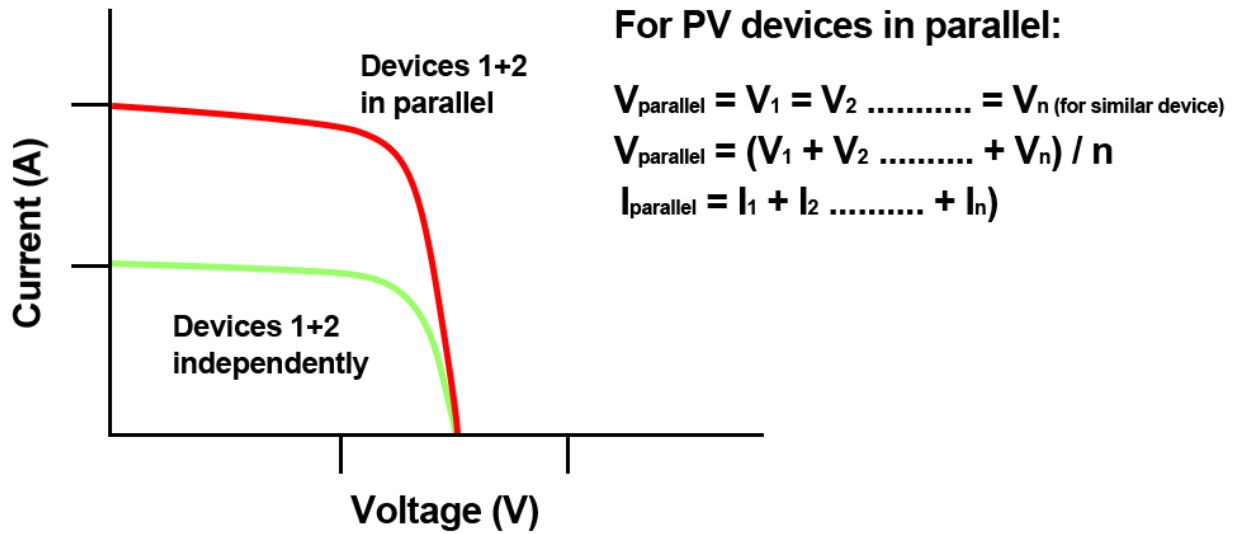

➤ Connecting Dissimilar PV Devices in Parallel

1. When PV devices with the same voltage but with different current output are connected in parallel, the individual currents add, and the voltage is the average of devices.

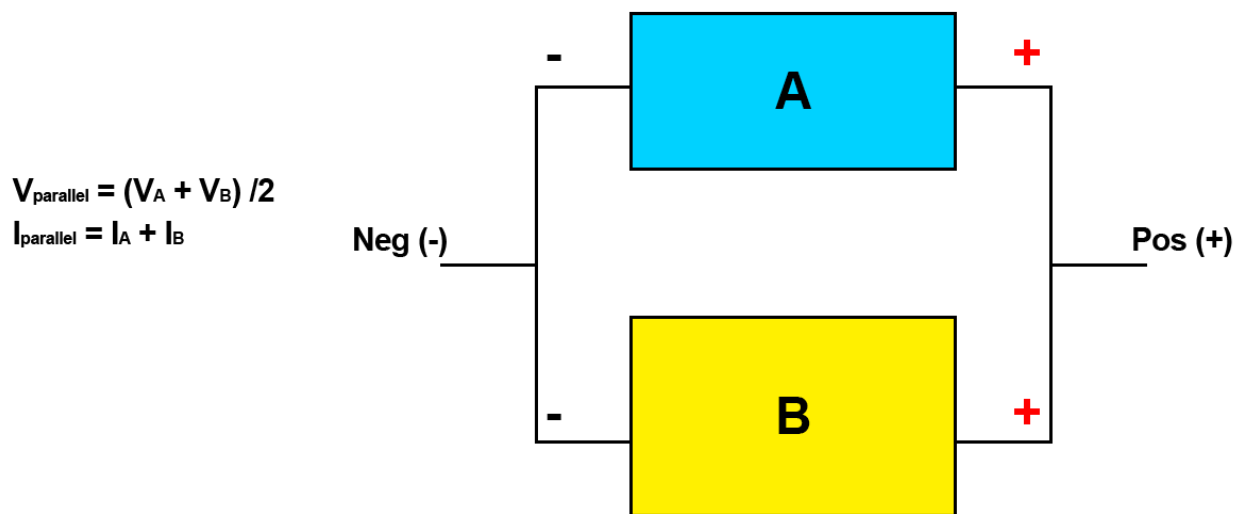

- Series strings of PV modules with similar voltage but having different current output may be connected in parallel.

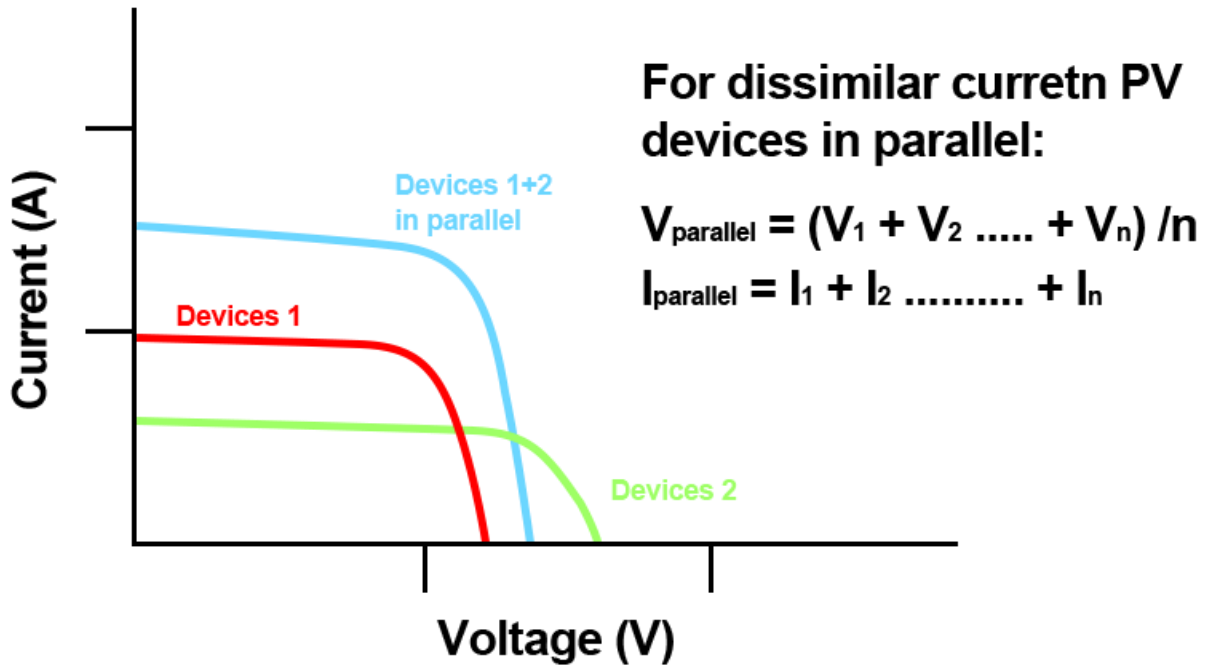

### ➤ Bypass Diodes

Bypass diodes are connected in parallel with series strings of cells to prevent cell overheating when cells or parts of an array are shaded.

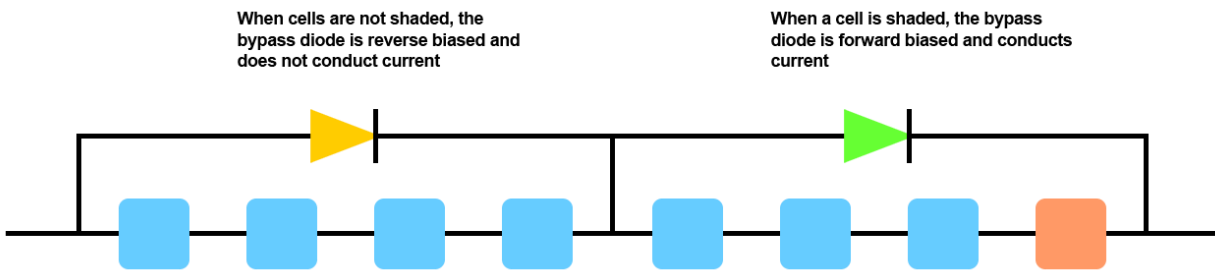

➤ Without Bypass Diodes

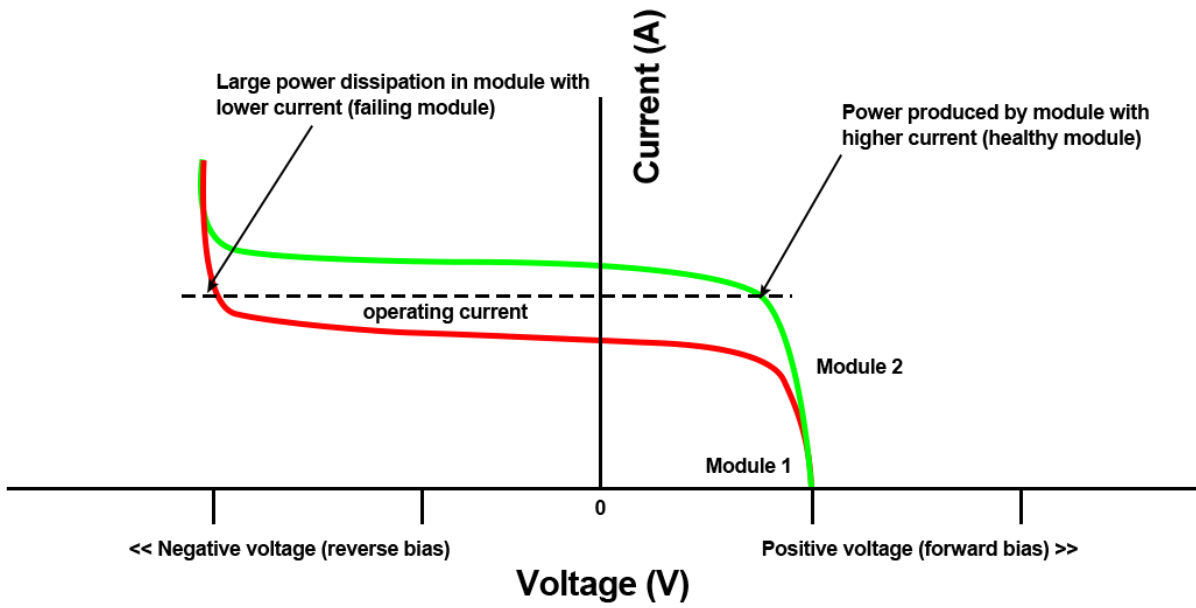

➤ With Bypass Diodes

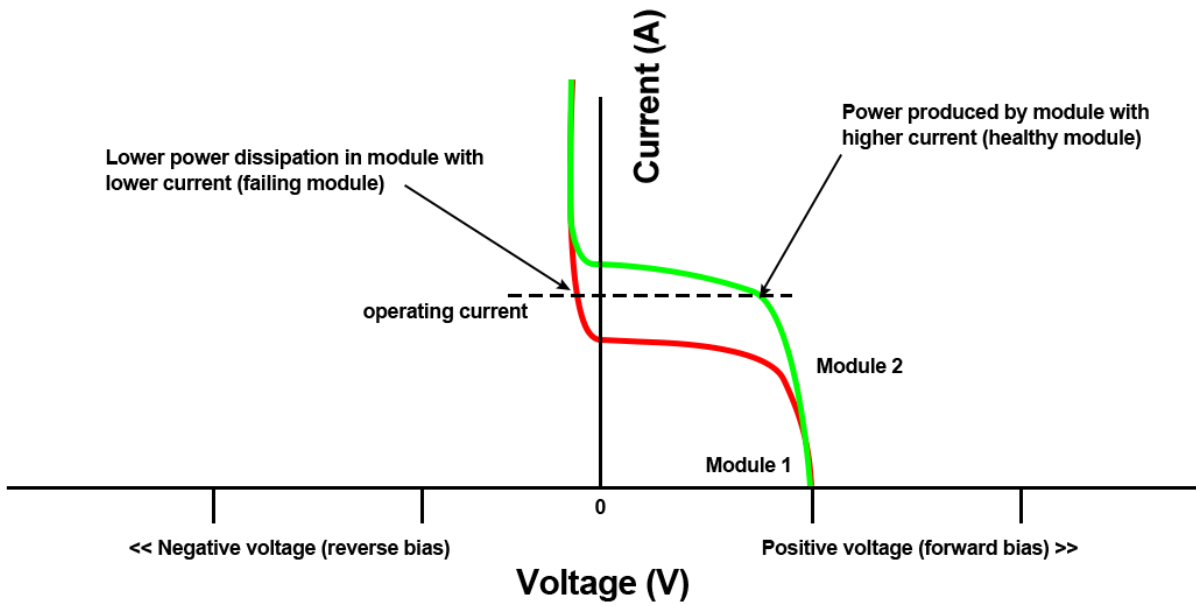

➤ Module Junction Box with Bypass Diodes



➤ PV Module Rating Conditions



		SW 245
Maximum power	$P_{max}$	245 Wp
Open circuit voltage	$V_o$	37.7 V
Maximum power point voltage	$V_{mpp}$	30.8 V
Short-circuit current	$I_{sc}$	8.25 A
Maximum power point current	$I_{mpp}$	7.96 A

## ➤ Other PV Module Ratings

1. Standard Operating Conditions (SOC)
  - Irradiance: 1,000 W/m<sup>2</sup>
  - Cell temperature: NOCT
2. Nominal Operating Conditions (NOC)
  - Irradiance: 800 W/m<sup>2</sup>
  - Cell temperature: NOCT
3. Nominal Operating Cell Temperature (NOCT)
  - Irradiance: 800 W/m<sup>2</sup>
  - Ambient Temp: 20°C
  - PV Array: open-circuit
  - Wind Speed: 1.0m/s
4. PVUSA Test Conditions (PTC):
  - 1000 W/m<sup>2</sup>, 45°C, 1 m/s

## ➤ PV Module Rating Conditions

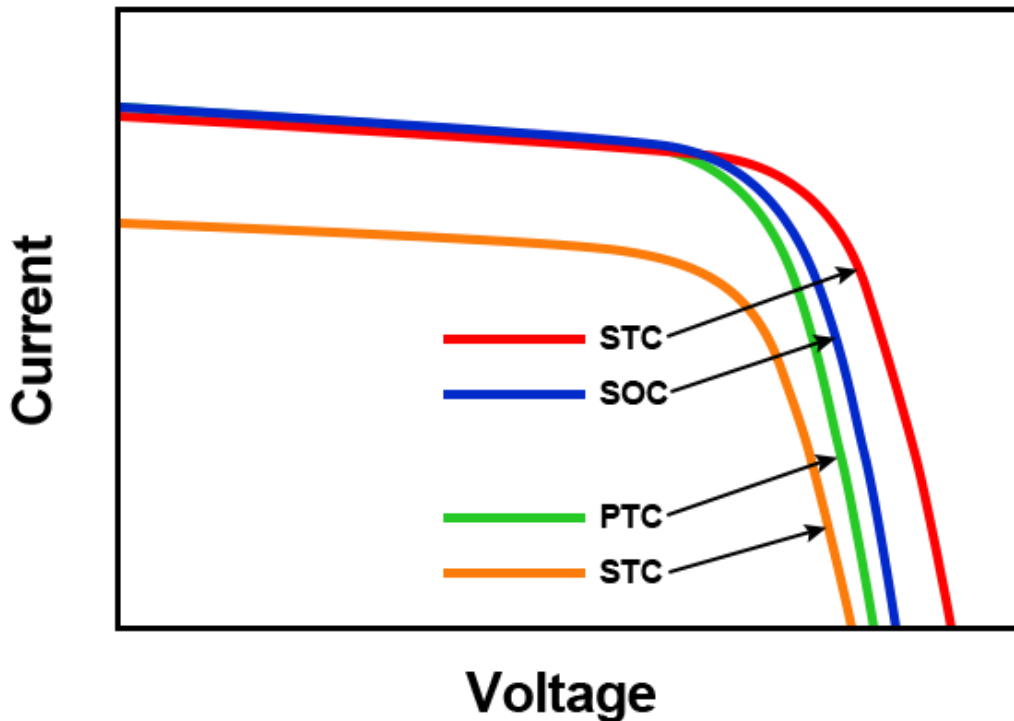

## ➤ Approved Modules

1. Certain listed PV modules have been approved as “eligible equipment” for California incentive programs.
  - See: [www.gosolarcalifornia.org](http://www.gosolarcalifornia.org)
2. These modules have had additional independent performance tests for PTC ratings.
3. Many other states refer to this list for eligible equipment for their incentive programs.

## ➤ Photovoltaic Modules Standards

1. Installation Requirements:
  - National Electrical Code, NFPA 70
  - Must be installed in accordance with manufacturer’s instructions
2. Product Listing
  - UL 1703: Standard for Safety for Flat-Plate Photovoltaic Modules and Panels
3. Design Qualification (reliability testing)
  - IEC 61215: Crystalline Silicon Terrestrial Photovoltaic (PV) Modules – Design Qualification and Type Approval
  - IEC 61646: Thin-Film Terrestrial Photovoltaic (PV) Modules – Design Qualification and Type Approval
4. Performance Measurements
  - ASTM E1036: Standard Test Methods for Electrical Performance of Non-concentrator Terrestrial Photovoltaic Modules and Arrays Using Reference Cells

## ➤ PV Modules Markings

All PV modules must be marked with the following information [NEC 690.51]:

1. Open-circuit voltage
2. Short-circuit current
3. Operating voltage
4. Operating current
5. Maximum power
6. Polarity of terminals
7. Maximum overcurrent device rating
8. Maximum permissible system voltage

## ➤ Fire Classification

1. PV modules may be evaluated for external fire exposure for building roof covering materials.
2. The fire class is identified in the individual Recognitions as class A,B or C in accordance with UL's Roofing Materials and Systems Directory.
3. Modules not evaluated for fire exposure are identified as NR (Not Rated), and not suitable for installation on buildings.

## ➤ PV Modules Design Qualification

1. PV modules attaining optional design qualification undergo additional reliability testing that validates long-term warranties.
2. The tests include:
  - Thermal cycling tests
  - Humidity – freezing tests
  - Impact and shock tests
  - Immersion tests
  - Cycling pressure, twisting, vibration and other mechanical loading tests
  - Wet/dry hi-pot, excessive and reverse current electrical tests
  - Other electrical and mechanical tests.

## ➤ Module Installation Instructions

1. Listed PV modules must be installed in accordance with instructions provided (shipped) with product.
2. Includes safety information, working with PV modules during sun hours (energized electrical equipment), mounting configurations, and electrical wiring and grounding instructions.

## ➤ PV Module Safety

1. Most manufacturer's literature states that module installation should be done by qualified, licensed electrical professionals.
2. Safety precautions for installing PV modules include:
  - Do not insert electrical conducting parts into the plugs or sockets.
  - Do not wear metallic jewelry while performing installation.
  - Do not fit solar modules and wiring with wet plugs and sockets. Tools and working conditions must be dry.
  - Exercise extreme caution when carrying out work on wiring and use the appropriate safety equipment (insulated tools/gloves, fall protection, etc.)
  - Do not use damaged modules. Do not dismantle modules. Do not remove any part or label fitted by the manufacturer. Do not treat the rear of the laminate with paint, adhesive or mark it using sharp objects.
  - Do not artificially concentrate sunlight on modules.

## ➤ Handling PV Modules

Care in handling, transporting, storing and installing PV modules includes the following:

- Leave modules in packaging until they are to be installed
- Carry modules with both hands, do not use connectors as a handle
- Do not stand modules on hard ground or on their corners
- Do not place modules on top of each other or stand on them
- Do not mark or work on them with sharp objects
- Keep all electrical contacts clean and dry
- Do not install modules in high winds

## ➤ Module Selection Criteria

The selection of PV modules for a given project may be based on any number of factors, including:

- Module physical and electrical specifications
- Manufacturer certification to quality standards (ISO 9000)
- Module warranty and design qualification (IEC 61215/61216)
- Customer satisfaction and field results
- Company ownership and years in business
- Costs and availability

## ➤ Summary

1. Photovoltaic (PV) cells are semiconductor devices that produce electrical output when exposed to sunlight.
2. The current-voltage characteristic (I-V curve) is the basic descriptor of PV device performance.
3. The output of a PV device is dependent upon sunlight intensity, temperature and electrical load.
4. PV devices are connected in series to build voltage, and in parallel to build current and power output.
5. PV modules are installed in accordance with installation instructions and local and local building codes.